

Flexible Duct

The Shower Fan  
screwed to the joist

Internal Grille

External Grille

## INSTALLATION INSTRUCTIONS

**MANROSE**  
CLASSIC SERIES

### CLASSIC IN-LINE CENTRIFUGAL FANS

Thank you for selecting our Manrose Centrifugal 100mm In-Line Fan Kit. Please read all instructions before commencing installation.

1. First select the grille you prefer in your room. There are two designs a circular ceiling grille which we recommend as the interior grille, and a fixed louver design which is suitable for the exterior.
2. The interior grille comes in two parts, the chassis (or spigot) and the circular fascia. If using fixing clips cut a 115mm hole in the ceiling ensuring first that the area above is free from obstruction. Alternatively cut a 105mm hole.
3. Fit 2 fixing clips supplied to the grill chassis then push chassis (or spigot) section into the hole in the ceiling. Alternatively mark the position of the fixing holes on the ceiling. Drill the holes and screw the grille chassis to the ceiling then refit the fascia to the chassis by aligning the locking tabs and twisting clockwise to secure.
4. Select a suitable place for the Fan to be screwed to a joist and secure using two screws through the fixing bracket. The fan motor is of ball bearing design to prolong the life of the motor.
5. Select a suitable position either in the soffit or on an outside wall for the other grille (fixed louver), carefully remove the grille insert from its housing by levering gently at the sides with a small screwdriver. Cut a 110mm hole ensuring first that the area above is free from obstruction.
6. Attach one end of the flexible duct to the spigot with the duct tape provided and from the outside feed the duct through the hole until the grille chassis is flush with the soffit/wall. Mark the position of the fixing holes on the soffit/wall. Drill the holes and screw the grille chassis to the soffit/wall then refit the grille to the chassis.

**Note:** It is best not to cut the flexible duct until the grille has been screwed to the outside surface to avoid the possibility of cutting the duct too short.

7. Pull the flexible duct gently to the discharge spigot of the fan and cut it to length and connect to the fan with duct tape provided.
8. Connect the remaining piece of duct to the ceiling grille and onto the fan using the duct tape provided.

**Note:** Make sure wherever possible to keep the duct running in a straight line as this will improve the performance of the fan.

#### IMPORTANT

- Isolate the mains supply before making any electrical connections.
- This system should be installed by a qualified electrician.
- When fitting through an external wall, an external grille must be fitted at all times.
- Fan should only be installed by fixed wiring, a flexible cord should not be used.
- The appliance is not intended for use by young children or infirm persons without supervision.
- Young children should be supervised to ensure that they do not play with the appliance.
- Precautions must be taken to avoid the back-flow of gases into the room from the open flue of gas or other open-fire appliances when mounted in outside windows or walls.

We reserve the right to change specification without prior notice.



Manrose is proudly distributed by Simx Limited  
PO Box 14 347, Panmure, Auckland, NZ. Technical Support (09) 259 1662  
e: sales@simx.co.nz | www.simx.co.nz | www.manrose.com.au

Diagram W1

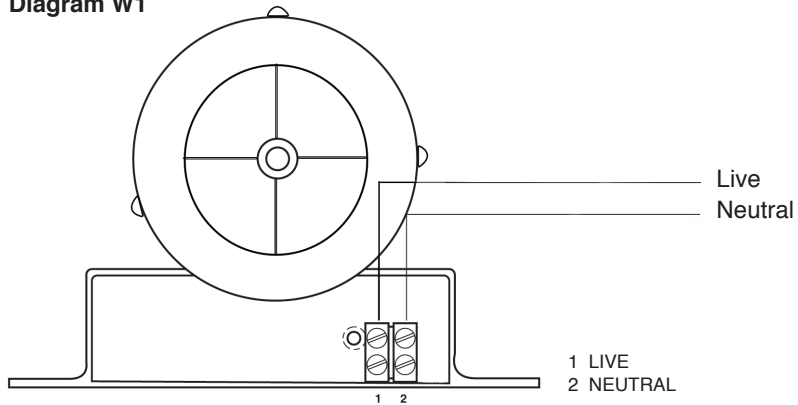
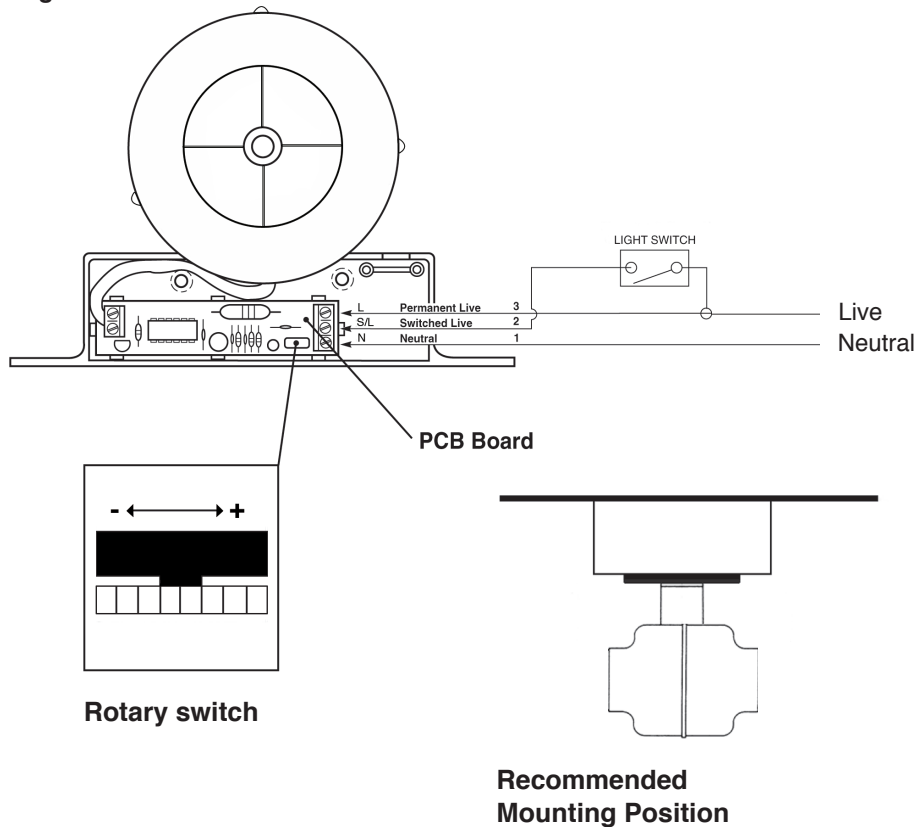

Diagram W2



9. Remove the cover on the Fan Bracket and make the electrical connection as follows:

**Wiring of Standard Model FAN0328 + FAN0326 SF200S (Diagram W1).**

The fan can be connected to the light switch so that the fan will start when the light is switched on, or a dedicated fan switch (not supplied). The fan should not be accessible to a person using either the shower or the bath.

**Note:** All wiring must be fixed securely and the cable to the fan should be a minimum of 1mm<sup>2</sup> in section. All wiring must comply with current Regulations. This system should be installed by a qualified electrician.

10. **Wiring of Timer Model FAN0329 + FAN0327 SF200T (Diagram W2).**

The fan can be connected to the light switch so that the fan will start when the light is switched on, or a dedicated fan switch (not supplied).

**Note:** All wiring must be fixed securely and the cable to the fan should be a minimum of 1mm<sup>2</sup> in section. All wiring must comply with current Regulations. This system must be installed by a qualified electrician.

When the light is switched off the fan will run for between 60 sec & 30 minutes (pre-set to 1 minute). The fan should not be accessible to a person using either the shower or the bath.

11. **Timer Adjustment only**

This time delay can be adjusted by firstly switching off the power to the fan and removing the cover. Locate the rotary adjuster as shown in **Diagram W2**. The serrated adjuster wheel can be rotated using a thumbnail to adjust the timer setting.

- + = Rotate to the right to increase the time (indicated by + on the diagram)
- = Rotate to the left to decrease the time (indicated by - on the diagram)

**Only adjust with power switched off.**

**Note:**

This unit is double insulated and therefore does not require an earth. The time delay is preset for approximately one minute and can be adjusted as described in paragraph 11. Try to keep the duct as straight as possible and wherever possible keep the distance between the ceiling grille and the external soffit or wall as short as possible as the shorter the length of duct the better the performance of the fan.

**Specifications**

Electrical:	220-230V ~ 50Hz <input type="checkbox"/>
Fan Wattage:	20W
IP Rated:	IP44
Airflow:	31l/s (110m <sup>3</sup> /hr)
Max Temp:	40°C

