



StoTherm Masonry Insulation
Energy-efficient insulation for
solid masonry facades

Energy-efficient insulation for solid masonry facades

In a typical dwelling, around 30% of the energy used to heat or cool a room is wasted due to poorly insulated walls. Sto external wall insulation systems dramatically cut energy loss by wrapping the building in a thermally-resistant envelope, helping to reduce energy bills and CO2 emissions. Sto insulation provides lasting protection for the entire fabric of the building.

Exterior insulation finishing systems embody our belief in, 'Building with conscience'.

Installing the right insulation harbours vast potential for new buildings. Furthermore, more than half of all houses that are over 30 years old are either inadequately insulated or lack any form of insulation at all. This leads to continual heat loss and vastly diminishes the quality of the home environment. As a rule, energy-efficient insulation actually saves more money than it costs – especially when installed during renovation work.

Cover: Bunurong Memorial Park, Victoria
Architect: BVN Architects

Right: Wanaka House, Wanaka
Architect: Richard Shackleton Architects



Insulate New Zealand's future

Insulation creates an agreeable indoor climate throughout the year.

High energy consumption comes at a high price – as becomes painfully apparent to many home owners when they take a look at their power bills. Many older buildings, as well as some newer ones, consume far more energy than they need to, because their insulation is not up to date. Apart from cutting costs, energy-efficient insulation also helps to protect the environment. This investment in the future benefits building owners and investors alike.

High quality, professionally installed insulation cuts heating costs, helps protect the environment and creates a pleasant indoor climate throughout the year. In the winter, insulation ensures a cosy and comfortable environment indoors, while in summer, maintaining a refreshingly cool interior.

Two factors are decisive here:

1. Thermal resistance of building materials used.
2. Avoidance of "thermal bridges" which allow valuable heat to escape.

Professionally installed Sto external wall insulation systems are free of thermal bridging and consist of building materials with minimal thermal conductivity.

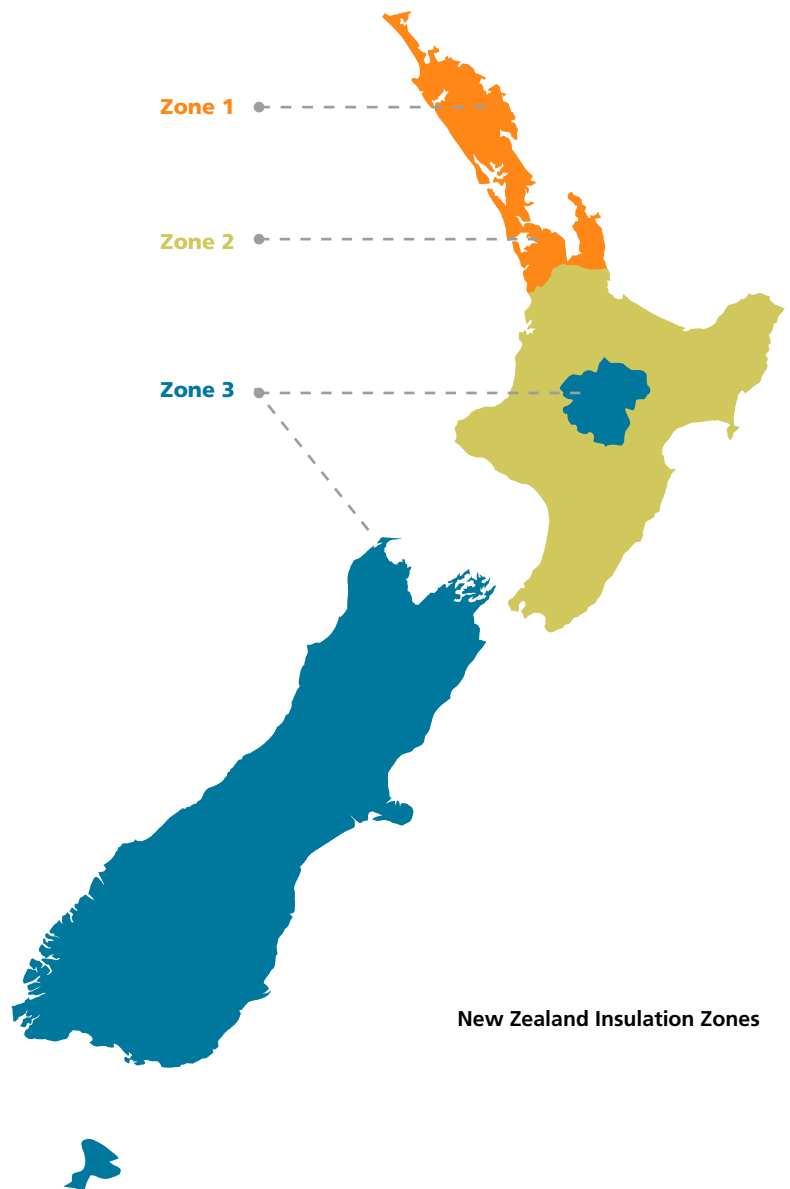

New Zealand Insulation Zones

R-values for different zones

	R-values non-solid construction			R-values solid construction		
	Zone 1	Zone 2	Zone 3	Zone 1	Zone 2	Zone 3
Roof	2.9	2.9	3.3	3.5	3.5	3.5
Wall	1.9	1.9	2.0	0.8	1.0	1.2
Floor	1.3	1.3	1.3	1.5	1.5	1.5
Vertical Glazing	0.26	0.26	0.26	0.26	0.26	0.26
Skylights	0.26	0.26	0.31	0.26	0.26	0.26

Required layer thickness of different building materials to achieve the same R values (in cm)

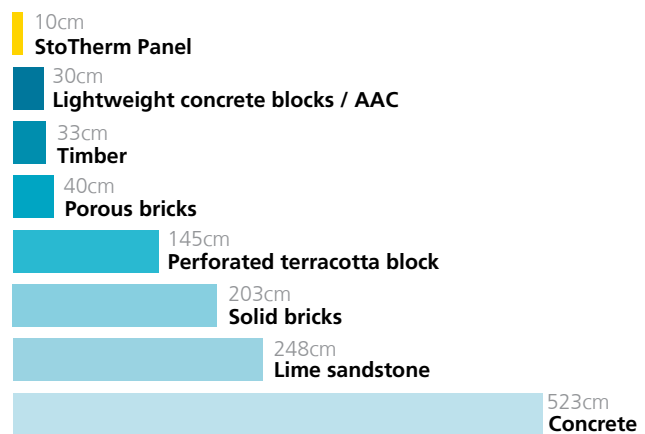

All building material layers have the same thermal resistance: $R = 2.50 \text{ m}^2\text{K/W}$

Requirements for better energy efficiency

In August 2007, the Department of Building and Housing announced major changes to Clause H1 of the Building Code, which deals with energy efficiency, thermal storage and insulation. The changes include, amongst other things, increased insulation requirements and an increased recognition of the appropriate use of thermal mass.

The requirements affect all houses, and other buildings with a floor area less than 300m².

The country is split into three zones. All new homes and major extensions across New Zealand will be required to meet the insulation requirements.

The amount of heat transmitted by a building material has nothing to do with its thickness

The R-value unit : [m²*K/W]; is the resistance to heat flow of a given component of a building material. It means, the higher the R-value, the greater the insulation provided. The lower this value, the poorer the material's insulating properties – irrespective of its thickness or the individual installation scenario.

Changes to the building code regulations mean that new houses will need to achieve higher R-values. Typically, walls, windows and roofs will require insulation modelling so that the sum of the components achieves the required R-value.

Thermal bridges

Costly heat stays indoors with Sto

Avoiding thermal bridges prevents the escape of expensive heat

Thermal bridges are points at which more heat is able to escape into the outside environment during heating periods than through the rest of the exterior envelope. This leads to increased heat losses, often accompanied by mould formation. Parts of structures which are frequently critical in this respect include, shutter boxes; balconies; window frames; window lintels; radiator attachments in the masonry; radiator niches; ceiling junctions; and corners in houses. Professional insulation reduces thermal bridging and subsequent structural damage, thus avoiding negative effects on a building's energy balance.

Annual heat losses for a detached house

Heat losses can be cut by almost 70% by installing modern windows and insulating the entire external envelope.

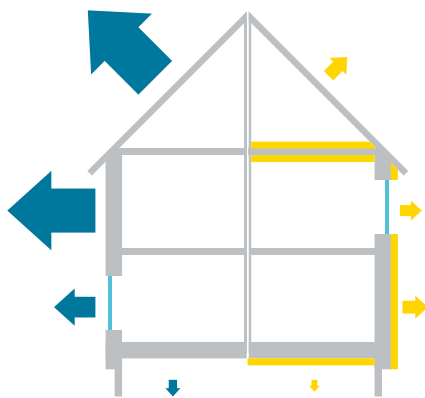

- Insulated
- Un-insulated



Residential, Stuttgart
Architect: architekten BDA Fuchs, Wacker

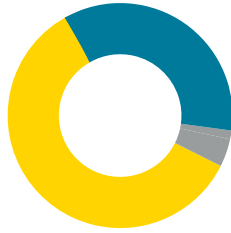

Breakdown of energy consumption by private households

Heating and cooling costs make up by far the largest proportion of private energy consumption.

- approx. 59% Heating and cooling
- approx. 33% Machines, pumps, communication and cooking
- approx. 8% Lighting



StoTherm insulation through thermography.

Detecting thermal bridges with thermography

Heat losses through the facade can be identified with the aid of infrared thermography. A thermographic camera produces coloured images indicating various levels of heat emission from buildings. The lighter the colour, the poorer the thermal insulation at a given point.

Thermal bridging? Not with Sto's technology of countersunk and capped anchors

A thermal bridge is created when poor insulators create a path for heat to flow through. Insulation around a bridge is of little help in preventing heat loss and in order to eliminate the problem insulation needs to be introduced over the bridge.

Sto has devised a solution to terminate thermal bridges caused by face fixed fixings and avoid unsightly spots appearing on the facade during cold weather. The StoTherm Anchor, designed for masonry and timber frame construction, is screwed in with an ST Fixing Tool which cuts and compresses StoTherm Panels to a depth of 20mm, leaving the anchor securely fastened into the substrate. After installation, the anchors are then capped with ST Insulation (EPS) Caps, resulting in a covered anchor with no thermal bridging and a smooth homogeneous surface ready to be rendered.



StoTherm Anchor installed on a masonry substrate.

A comfortable home environment begins with the walls

Sto provides for uniform ambient room temperatures

The perceived ambient room temperature results from the heat of the room air and the temperature of the surrounding wall surfaces, including the ceiling and flooring. The cooler the walls, the higher the air temperature needs to be in order to ensure an ideal indoor climate. In addition to reducing heat losses, a professionally insulated facade produces a higher wall surface temperature at the same air temperature.

Mould – a threat to health and building environments

Cold air absorbs less moisture than warm air, which is a particular problem in homes in the winter, as moisture condenses on cold parts of the building. Wall areas, which are subject to damp penetration as a result of thermal bridging, provide an ideal habitat for mould. This is harmful not only to the building environment but also to health. Moisture arises from all types of in-house activity, from cooking and baking, through to washing and showering, and even keeping house plants. In order to avoid exposing parts of structures to damp penetration, it is necessary to eliminate thermal bridges at the planning stage. Proper heating and ventilation is also crucial at all times.

Correctly installed EIFS protect entire walls, maintaining a warm and dry substrate. Protected in this way, substrate temperatures are maintained above the dew point. This effectively deals with damp, mould growth and other environmental issues.

Un-insulated Wall



Internal wall insulation



Exterior wall insulation

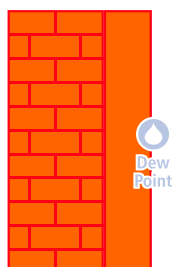

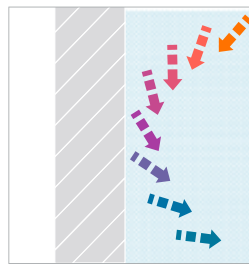

Warm room air cools on contact with a cold un-insulated wall. This results in a continual draught and can create an uncomfortable room environment.

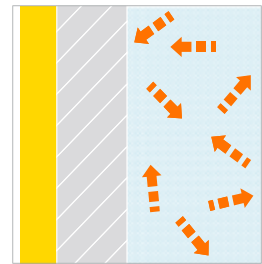

With facade insulation, wall temperature is close to room temperature. This results in steady air movement, while the higher wall temperature prevents mould formation.

Internal insulation

While internal insulation allows a room to be heated quickly, this is its only plus point. The temperature curve is poor and the external wall remains vulnerable to the elements. The heat retention capability of the existing wall is not utilised in winter and is susceptible to an internal dew point, resulting in condensation, damp and mould. In summer, the process is reversed with the masonry wall heating the interior environment, creating overly-hot conditions.

Save as you preserve your building environment

Insulation pays on existing and new buildings alike

StoTherm: Refurbishment
Aorangi House, Wellington
Architect: Studio Pacific Architecture

A new building affords the opportunity to create energy efficiency from the outset. Aside from the ecological merits, this also pays in economic terms for building owners and investors. Existing buildings harbour even greater potential, with well over half being in urgent need of energy-efficiency measures; a veritable “energy-saving Eldorado” – especially amongst houses over 30 years old with an inadequate standard of insulation.

Insulating existing buildings

Since every house is in need of restoration at some point in time, good planning and scheduling insulation systems can boost savings. The energy efficiency of the majority of existing buildings can be improved substantially with external wall insulation systems from Sto. The current condition of any house should always be assessed first by a specialist, so that any building damage can be incorporated into an overall restoration solution. Good planning cuts costs: Installing scaffolding pays off much more quickly, for example, if a new coat of paint, crack repair work or window replacements are due to be carried out anyway and insulation can be installed at the same time.

Insulating new buildings

Correct planning and execution pay off from day one. A whole range of energy factors need to be considered when designing a new building. These factors include, orientation and location of the house; ratio of exterior surface area to enclosed space; room layout; heating system; windows; and facade insulation. It is particularly important to choose the correct insulant and appropriate insulant thickness. Not only does an ideally designed EIFS reduce energy costs, it also provides long-term protection for the building environment.



**StoTherm: New build
Residential, Offenburg
Architect: Dipl.Ing. Koger, Krongutstr.**



Insulating is worthwhile ecologically...

Heating energy which heats the environment rather than the home makes neither ecological nor economic sense. The rise in CO₂ emissions is a major cause of global warming, with catastrophic consequences such as a drastic increase in hurricanes and flooding etc. Energy-efficient insulation helps preserve and resources actively contributes towards protecting the environment and climatic conditions.

and economically

Insulation costs for facades, roofs and flooring pay off quickly - and with noticeable effects, as heating costs are by far the largest share of energy expenditure for private households. In principle, the better the insulation, the higher the savings potential. Insulating the facade alone cuts heating costs by 30-40%. In the face of annual price increases, such as presently apply to fuel oil, modernisation measures quickly prove worthwhile.

StoTherm Masonry Insulation System

Well-engineered down to the finest detail

Over 50 years of development and carefully chosen components have made StoTherm Insulation Systems a durable, functional and versatile choice for meeting and exceeding building insulation requirements. StoTherm has by far the lowest complaints quota in the market – and for good reason. It was the first EIFS subjected to reliability and long-term material quality tests right from the start and certified by the Passivhaus Institut Darmstadt. 100 million m² of StoTherm has been installed around the world; evidence enough that StoTherm is not only one of the best insulation systems around but also one of the most economical.

Installations are carried out by a Sto Registered Licensed Building Practitioner, with the added protection of a StoArmat 15 or 20 Year Warranty and StoService Assurance, guaranteeing building code compliant materials are used and the application meets building code standards, including a service plan for long-term security.

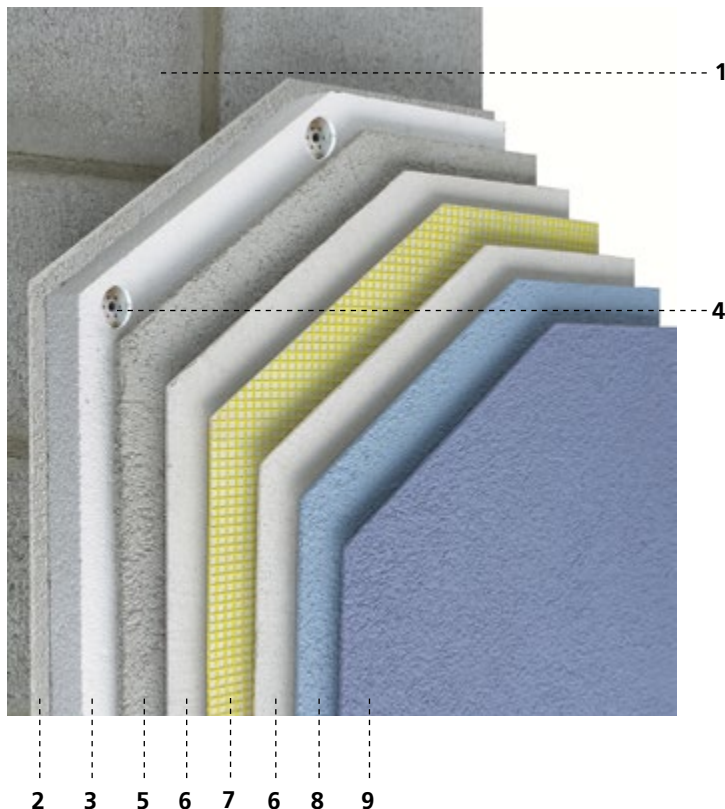

StoTherm Armat Insulation System

1. Substrate: Solid masonry

Such as concrete blocks, precast, brick & insitu concrete

2. Adhesive: Gluecoat Mortar

3. Insulation (EPS): StoTherm or StoTherm+ Panel

40/100mm self-extinguishing panel, manufactured to AS 1366 Pt 3 by an approved manufacturer.

4. Fixing: StoTherm Masonry Anchors

Drill, install, countersunk and capped with an ST Insulation Cap to avoid thermal bridging.

5. Basecoat: StoLevell Novo / LevelLite Render

Lightweight, EPS bead mineral render with good build properties, water retention agents and machine application properties.

6. Reinforcement Render: StoArmat Render

An organic, weather resistant, cement-free and breathable, high-impact render, with a crack resistance six times higher than that of standard cement-based plasters.

7. Mesh: Sto Glass Fibre Mesh

Easy-to-install, meets the highest requirements for crack, stress and alkalinity resistance.

8. Coloured Finishing Renders: Stolit Renders

Organically bound, highly weather resistant, strong, hard-wearing, impact-resistant, pre-coloured finishing renders.

9. Facade Paint: StoColor

StoColor coating based on IQ Net Technology for functional facades.



StoArmat 20 Year Warranty
with StoService Assurance

StoTherm Vario Insulation System

Mineral based - similar to traditional New Zealand systems

The StoTherm Vario Insulation System is a low cost, EPS expanded polystyrene insulation system and is the ideal choice for those seeking to combine the advantages of a light, organic insulant with mineral-based reinforcement render and a selection of finishes.

All StoTherm builds are specified by Sto and implemented by a Sto Registered Licensed Building Practitioner, with a 15 Year StoWarranty, Contractor Guarantee and StoService Assurance provided. Delivering an economically sound and practical solution for all your facade requirements.

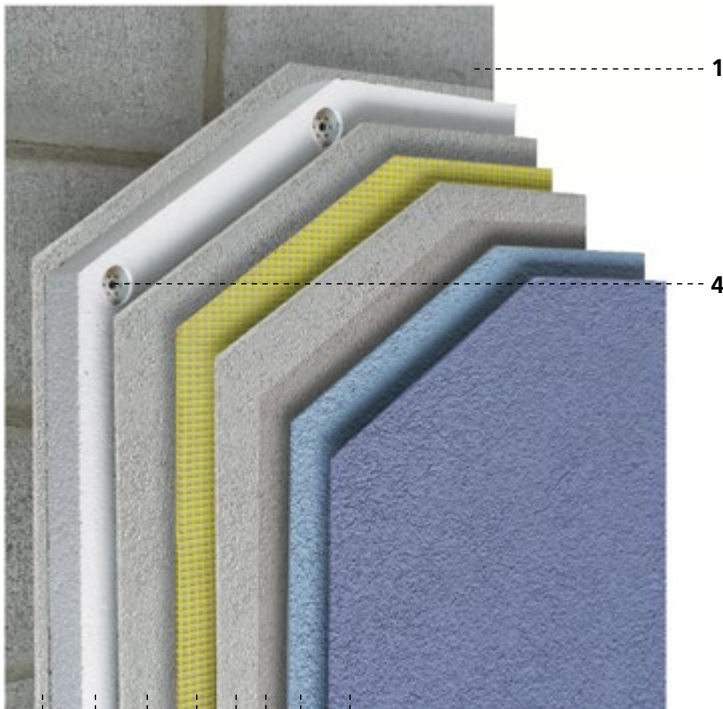

2 3 5 6 5 7 8 9

StoTherm Vario Insulation System

1. Substrate: Solid masonry

Such as concrete blocks, precast, brick & insitu concrete

2. Adhesive: Gluecoat Mortar

3. Insulation (EPS): StoTherm or StoTherm+ Panel

40/100mm self-extinguishing panel, manufactured to AS 1366 Pt 3 by an approved manufacturer.

4. Fixing: StoTherm Masonry Anchors

Drill, install, countersunk and capped with an ST Insulation Cap to avoid thermal bridging.

5. Basecoat : StoLevell Novo / Levell Uni Render

White mineral renders with good adhesion and a calibration grain.

6. Mesh: Sto Glass Fibre Mesh

Easy-to-install, meets the highest requirements for crack, stress and alkalinity resistance.

7. Sealer: StoPlex

Water-based, siloxane-enhanced sealer with water repellent and stability properties.

8. Coloured Finishing Renders: Stolit Renders

Organically bound, highly weather resistant, strong, hard-wearing, impact-resistant, pre-coloured finishing renders.

9. Facade Paint: StoColor

StoColor coating based on IQ Net Technology for functional facades.



BRANZ appraisal 604



Sto 15 Year Warranty with StoService Assurance

StoTherm Panels

Achieving the right R-values

StoTherm Masonry Insulation Systems consists of 40 to 100mm and over thick EPS StoTherm Panels or StoTherm⁺ Panels to suit your building requirements. The StoTherm⁺ Panel insulation properties provide better energy efficiency and savings increasing R-values by up to a further 20%.



StoTherm Panel



StoTherm⁺ Panel

R-Value comparison of StoTherm Panel and StoTherm⁺ Panel

Thickness	StoTherm Insulation Panel	StoTherm ⁺ Insulation Panel
40mm	1.00	1.30
50mm	1.30	1.60
60mm	1.57	1.93
80mm	2.10	2.58
100mm	2.63	3.22

EPS Panel thickness above 100mm available.

StoTherm Anchors

An innovative solution

Innovative anchors from Sto eliminate thermal bridging whilst removing those unsightly moisture spots in cold weather. The detail below illustrates a typical system detail of our new StoTherm Eco Twist, self embedding anchor, StoTherm Counter Sunk Anchor and also the StoTherm Impact Anchor.

StoTherm Eco Twist, self embedding anchor

For 100mm to 400mm StoTherm Panel,
(eliminates thermal bridging).

Concrete / Masonry Block
Sto Adhesive Mortar
StoTherm Panel

StoTherm Eco Twist Anchor
StoArmat Miral Render System

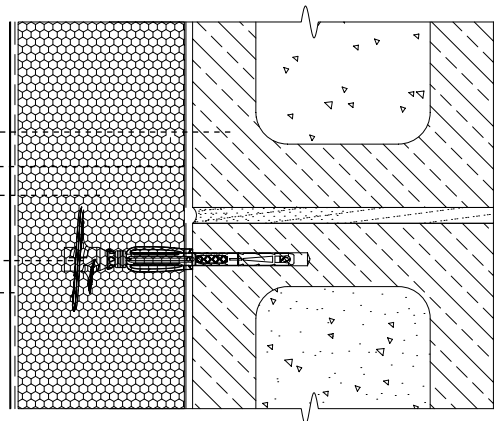

StoTherm Countersunk Anchors

For 60mm, 80mm or 100mm StoTherm Panel,
(eliminates thermal bridging).

Concrete / Masonry Block
Sto Adhesive Mortar
StoTherm Panel

StoTherm Counter Sunk Anchor
StoTherm Insulation Cap
StoArmat Miral Render System

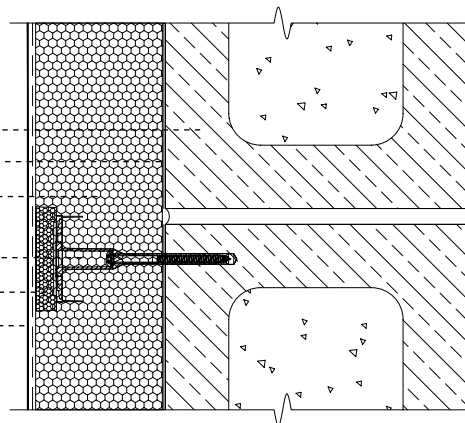

StoTherm Impact Anchors

For faced fixed fixings, 40mm, 50mm, 60mm or 80mm StoTherm Panel.

Concrete / Masonry Block
Sto Adhesive Mortar
StoTherm Panel

StoTherm Impact Anchor
StoArmat Miral Render System

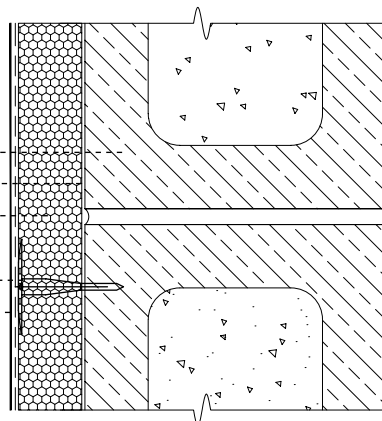

Head Office

Wellington

Stoanz Ltd
72 Abel Smith Street
Wellington, New Zealand
Phone +64 4 801 7794
Fax +64 4 384 9828

General Enquiries

Phone +64 4 801 7794
Email info@sto.co.nz
Web www.sto.co.nz



New Zealand Offices

Auckland

1 George Street, Mount Eden
Auckland, New Zealand
Phone +64 9 522 1058
Fax +64 9 522 1054

Tauranga

Phone +64 4 801 7794
Mobile +64 27 299 9290

Christchurch

47A Waterloo Road, Hornby
Christchurch, New Zealand
Phone +64 3 338 3570
Fax +64 3 338 3571

Queenstown / Wanaka

Phone +64 4 801 7794
Mobile +64 27 453 3240

Australian Offices

Sydney

Stoanz Australia Ltd
7 Mitchell Street, Marrickville
Sydney, NSW, Australia
Phone +61 2 9560 9589
Fax +61 2 9572 6003
Email info@stoau.com.au
Web www.stoau.com.au

Melbourne

Mobile +61 451 234 525