



 JURALCO

**JURALCO EDGETEC® POSIGLAZE™
BALUSTRADE SYSTEM**

ISSUE 10-25 v1

6.03.26

Juralco Aluminium Building Products Ltd designs and distributes specialist aluminium joinery systems through a national network of franchised fabricators and agents. For more than 25 years we have been at the forefront of specialist aluminium door and window products suitable for New Zealand joinery and building methods. Our comprehensive product range includes security and insect screens, balustrades and gates, shutters and awnings, shower screens, wardrobe doors and organisers and internal doors.

The Juralco Edgetec® PosiGlaze™ Balustrade System is designed for Frameless Glass, from 12mm to 21.52mm, either Base or Side fixed and for Residential or Commercial use. An Interlinking Top Rail (depending on Glass type) may be used.

The system is extremely versatile and can be made in a range of configurations to suit most modern architectural requirements and Wind Zones.

PosiGlaze System - Product Overview

The PosiGlaze System was developed for cantilevered structural balustrades for Toughened Safety Glass (TSG) and Toughened Laminated Safety Glass (TLSG). The unique design uses a special high strength hollow-core aluminium extrusion and special glass clamp kits that secure and locate the glass into the aluminium section. This means the system can be used on 12 & 15mm TSG; and 13.52, 17.52 & 21.52 TLSG with SAFELITE® STF (Sentry®) Interlayer; all without holes in the glass.

The PosiGlaze System can be Base or Side fixed. PosiGlaze's clever locating and adjusting technique allows installers to adjust the glass panels once in place, with a turn of a spanner, saving on installation time. Simple to install, align and adjust.

Fully adjustable after installation: PosiGlaze uses a unique, simple adjustment system allowing horizontal alignment of each glass panel.

Lightweight and extremely strong: Cleverly designed out of extruded aluminium, saving weight yet keeping strength.

Engineered: Our system has been engineered & tested to comply with the building regulations (with the appropriate fixing spacing and glass thickness) in both domestic and selected commercial installations. It can be installed in a wide variety of applications.



Juralco Edgetec® PosiGlaze™ Balustrade System

Complies With AS/NZS 1170:2002, NZS 4223.3.2016, NZ Building Code B1, B2, F2, F4 and F9

**For Residential Occupancy Types A, A Other and C3
and for Commercial Occupancy types B, E, C3, C1/C2 and D
Occupancy Types as per AS/NZ 1170.1.2002. Not suitable for Commercial C5 applications**

Code	Type of Occupancy for part of the building or structure	Specific Uses	Glass
A	Domestic and Residential activities	All areas within or serving exclusively one dwelling including stairs, landings etc, but excluding external balconies and edges of roofs.	12mm Toughened Glass, 13.52mm SentryGlas® 15mm Toughened Glass 15.2 mm Laminated Glass 17.2mm Laminated Glass 17.52mm SentryGlas® 21.52mm SentryGlas®
B, E	Offices and work areas not included elsewhere including storage areas.	Light access stairs and gangways not more than 600mm wide Fixed platforms, walkways, stairways and ladders for access Areas not susceptible to overcrowding in office and institutional buildings; also industrial and storage building.	
A Other, C3	Areas without obstacles for moving people and not susceptible to over crowding	Stairs, landings, external balconies, edges of roofs etc.	

masterspec partner
Section 4852JB

Note 1 Juralco Balustrade Systems building code compliance documentation requires all balustrade installations are to be completed in accordance with the requirements of our authorised installer certification.

Note 2 Frameless Glass Balustrades must conform to NZS 4223.3.2016
See individual Layout pages for conformance details

Note 3 The Dulux powder coating warranty period is conditional upon the Balustrade being maintained in accordance with the Dulux 'Care and Maintenance Instructions'. See Page 5 for warnings concerning Coastal conditions.
Contact your balustrade installer for a copy of the Care and Maintenance procedure.

Index

Heading	Pages	Description. Use the Bookmarks  List to jump to selected pages
Specifications	4	Juralco standard specification sheet and Powder coating recommendations
All Sections Below for Side Fix only		
Configurations	5 - 6	Shows typical elevation layouts for all Glass types
Pool Fencing	7	Shows Side Fix used for Pool fencing
General	8	Shows Side Fix Clamp Cross section and all details
Stairs	9	Shows Connections for Stairs
Components	10 - 12	Shows all Components, Extrusions and Kits
Wind Zones, BH. Face Fix	13	Shows Wind Zones, Balustrade Heights and widths, for Glass Thicknesses, Types.
Site Specific Info	14	Shows information to Enable Project Engineers to develop Site Specific designs
Mountings	15 - 23	Shows Mounting details, all for Side Fixed. Timber (p13-17), Steel (p18-20) and Concrete (p21)
	24	Shows Suspended Deck Mounting details Side Fixed.
All Sections below for Base Fix only		
Configurations	25- 26	Shows typical elevation layouts for all Glass types
Pool Fencing	27	Shows Base Fix used for Pool fencing
General	28	Shows Base Fix Clamp Cross section and all details
Wind Zones, BH. Top Fix	29	Shows Wind Zones, Balustrade Heights and widths, for Glass Thicknesses, Types.
Site Specific Info	30	Shows information to Enable Project Engineers to develop Site Specific designs
Mountings	31 - 35	Shows Mounting details, all for Base fixed. Timber (p31-32), Steel (p33-34) and Concrete (p35)
	36	Shows Suspended Deck Mounting details Base fixed.
Installation for Face and Top Fix		
Installation	37	Base and Side Fix recommended Installation Guide
Glass Top Edge - Safety		
Glass Panels. Top edge. Safety	38- 47	Shows all Interlinking Rail options (5 x Total). Swivel connectors and End connections
	48	Shows Glass stiffener brackets, Fixed and Adjustable angles
End Brackets	49 - 51	Shows Interlinking Rail End bracket attachments to Posts and Structures
Rail mounted to Glass Panel	52	Shows Interlinking Rail Side mounted to a Glass Panel and all End brackets
Joiners and End Plates	53 - 54	Shows Interlinking and Handrail Joiners and End Plates
Surface Care	55 - 57	Instructions for the care of Glass, Powder Coated and Stainless Steel surfaces

Juralco Edgetec® PosiGlaze™ Balustrade System
Juralco Aluminium Building Products Ltd (JABP)
Specifications for Juralco Edgetec® PosiGlaze™ Balustrade System

1.Scope

- This specification details the documents the Juralco Edgetec® PosiGlaze™ Balustrade System refers to in relation to the New Zealand Building Code, the manufacturer's documents, products used in the System, requirements in relation to fixing and surface finishing.

2. NZBC Compliance

- The Juralco Edgetec® PosiGlaze™ Balustrade System has been reviewed by Lautrec Technology Group Ltd to demonstrate compliance with the structural requirements of the New Zealand Building Code and NZS 1170 : 2002 occupancy A, B, E ,A Other and C3, NZS 3604 up to and including Extras High Wind Zone.
- The Structural Engineering design includes the requirements of B1 Structure, B2 Durability, F2 Hazardous material and F4 Safety from falling, all from the Building Code.
- Glass used in the Juralco Edgetec® PosiGlaze™ Balustrade System must conform to AS/NZS 2208. Complies with NZS 4223.3.2016
- Separation of dissimilar materials (as relates to B2 compliance) have been reviewed.
For other combinations refer to NZS 3604:2011 Section 2.3.3 Separation and Section 4 Durability

3. Manufacturer's Documents

- The Juralco Edgetec® PosiGlaze™ Balustrade System manual details all extrusions and components used for the fabrication and installation/fixing of the system.
- A Producer Statement 1(Design) is available.
Copies of the above documents are available from:
Juralco Aluminium Building Products Ltd
48 Bruce McLaren Rd, Henderson, Auckland
Phone 09 478 8018 Fax 09 478 7883 Email specify@juralco.co.nz
- Any deviation from the standard fabrication or installation/fixing must be accompanied by a site specific PS1 with site specific calculations and drawings

4. Products

- Only extrusions, components and hardware supplied by or specified by JABP may be used in the Juralco Edgetec® PosiGlaze™ Balustrade System
- Aluminium extrusions, components and hardware – unless specified are manufactured to 6060 T5 specifications
- Stainless Steel components, hardware, fixings – all components to 304 or 316 grade
- Glass - all glass used in the Juralco Edgetec® PosiGlaze™ Balustrade System must conform to the specifications as listed in the Juralco Edgetec® PosiGlaze™ Balustrade System manual with each panel conforming to AS/NZS 2208 as confirmed by the Safety Stamp detailing the manufacturer's description and licence number.

5.Surface Finishing

- Juralco Aluminium Building Products Ltd is a Dulux Registered Applicator site, registration number 2101.
JABP uses only Dulux branded powder coating materials
- Dulux Duralloy® powder coating systems are suitable for properties greater than 100m from high tide level
AAMA 2603 performance. Residential buildings, 3 levels max. Warranty 10 yrs
- Dulux Duralloy Plus® powder coating systems are suitable for properties greater than 10m from high tide level.
AAMA 2603 performance. Residential and Light commercial buildings, 3 levels max. Warranty 15 yrs
- Dulux Duratec® powder coating systems are suitable for properties greater than 10m from high tide level
AAMA2603 and 2604 performance. All Residential and Commercial buildings. Warranty 25 yrs

6. Installation and Fixing

- The Juralco Edgetec® PosiGlaze™ Balustrade System must only be installed in accordance with the Juralco Edgetec® PosiGlaze™ Balustrade System manual
- Any deviation from that specified in the Juralco Edgetec® PosiGlaze™ Balustrade System manual must only be in accordance with the site specific PS1 with site specific calculations and drawings listing the non standard details.
Contact Juralco for more informations.
- The Juralco Edgetec® PosiGlaze™ Balustrade System must only be fabricated/installed by a Juralco approved fabricator
- Upon completion of the installation the fabricator must supply the Council with a PS3 (Construction)

Important information - Powder Coating systems.

Powdercoat Systems The new standard Dulux powder coating system used by Juralco is Duralloy Plus®. Also Duralloy® and Duratec®. All as per specs above. Juralco Powder coated prices are for Duralloy Plus® and Duralloy® (same pricing). Duratec® prices on application.

Attachment to structures A PVC Tape or similar material spacer must be used to separate powder coated aluminium items from all concrete and steel structures. Failure to do so can lead to the chemicals in the structure affecting the powder coating, leading to corrosion.

Swimming Pools The chlorinated water in swimming pools can cause the deterioration of powder coated surfaces, leading to corrosion of the underlying surface. It is recommended that Powder coated surfaces be 1200mm min from a pool.

Care The Dulux powder coating warranty period is conditional upon the surface being maintained in accordance with the Dulux 'Care and Maintenance Instructions'. Download from Dulux or refer to the back page of this manual.

Juralco Edgetec® PosiGlaze™ Balustrade System Typical Layouts - Side Fix

PosiGlaze Balustrade System Side Fix + Interlinking Rail

Glass must have a minimum strength of 100Mpa. Seen edges polished

Residential Occupancy types A, A Other and C3, for
 - 12mm Toughened
 - 15.2mm Laminated Glass
 - 13.52mm SentryGlas

Refer page, 'Allowable Heights for Side Fix Balustrade' for differing Wind Zones

See individual Mounting pages for construction options

Use 4 x Clamps per m

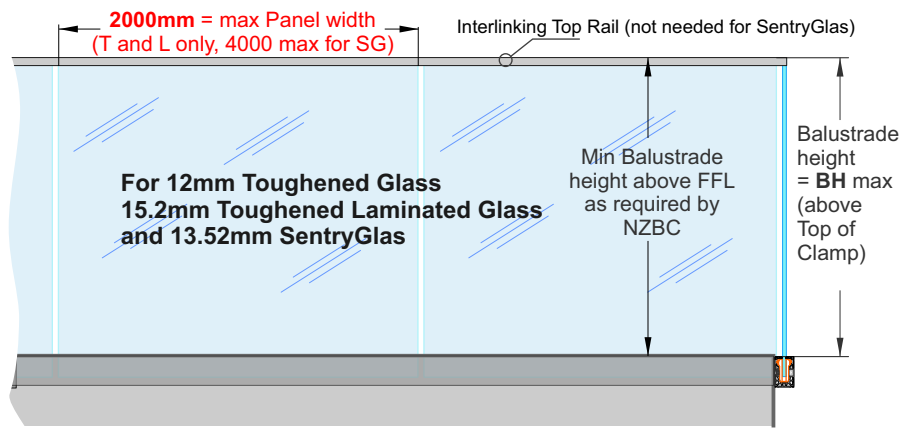

Exceeds the wind loading for all Wind Zones up to **and including Extra High Wind Zone** as set out in NZS 3604:2011

Refer to the Interlinking Top Rail pages for conformance to NZS 4223.3.2016.

PosiGlaze Balustrade System Side Fix + Interlinking Rail

Glass must have a minimum strength of 100Mpa. Seen edges polished

Commercial Occupancy types B, E and C3, for
 - 15mm Toughened
 - 17.2mm Laminated Glass
 - 17.52mm SentryGlas

Refer page, 'Allowable Heights for Side Fix Balustrade' for differing Wind Zones

See individual Mounting pages for construction options

Use 4 x Clamps per m

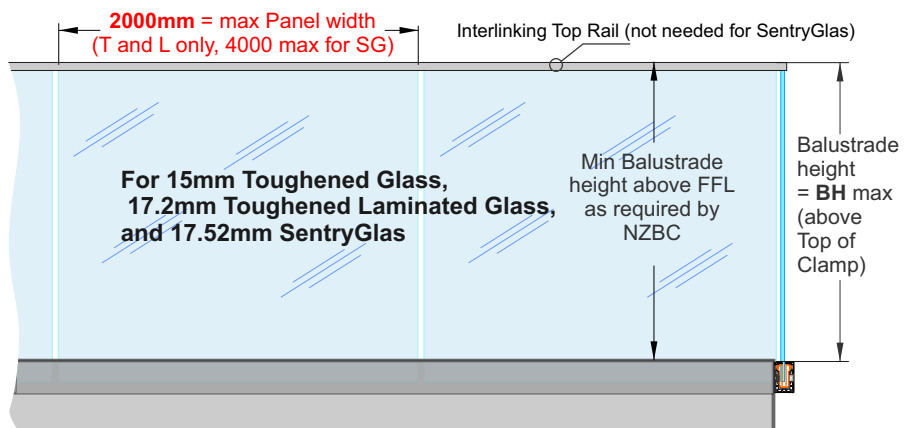

Exceeds the wind loading for all Wind Zones up to **and including Extra High Wind Zone** as set out in NZS 3604:2011

Refer to the Interlinking Top Rail pages for conformance to NZS 4223.3.2016.

PosiGlaze Balustrade System Side Fix

POOL FENCING only

Glass must have a minimum strength of 100Mpa. Seen edges polished

Applies to Swimming Pools as of Jan 2017, complies with the Building Code clause F9 and section 162C of the Building Act.

Applies to Pool Fences not protecting a fall of 1.0m or more

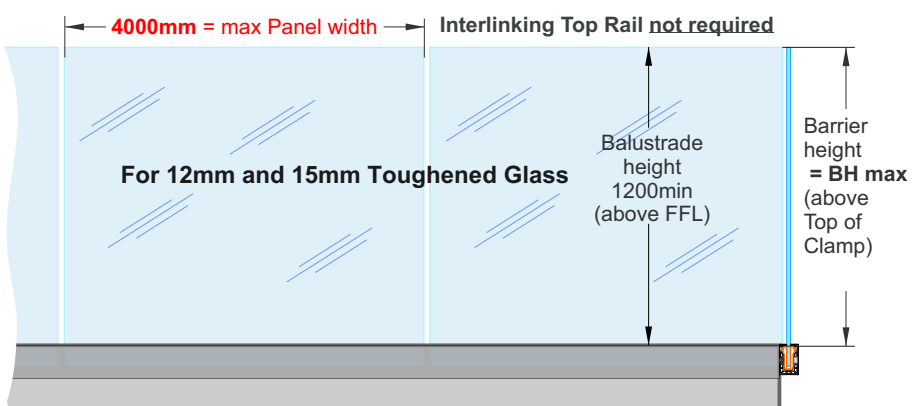

12mm Toughened - Up to and including **Very High Wind Zone.**

15mm Toughened - Up to and including **Extra High Wind Zone**



JURALCO

www.juralco.co.nz ph (09) 478 8018

Juralco Edgetec® PosiGlaze™ Balustrade System

Issue 10-25 v1

Page 5

Juralco Edgetec® PosiGlaze™ Balustrade System Typical Layouts - Side Fix

PosiGlaze Balustrade System Side Fix + Stiffener Brackets

Glass must have a minimum strength of 100Mpa. Seen edges polished

Residential Occupancy types A, A Other and C3, for
- 15.2mm Laminated Glass
- 13.52mm SentryGlas

Refer page, 'Allowable Heights for Side Fix Balustrade' for differing Wind Zones

See individual Mounting pages for construction options

Use 4 x Clamps per m

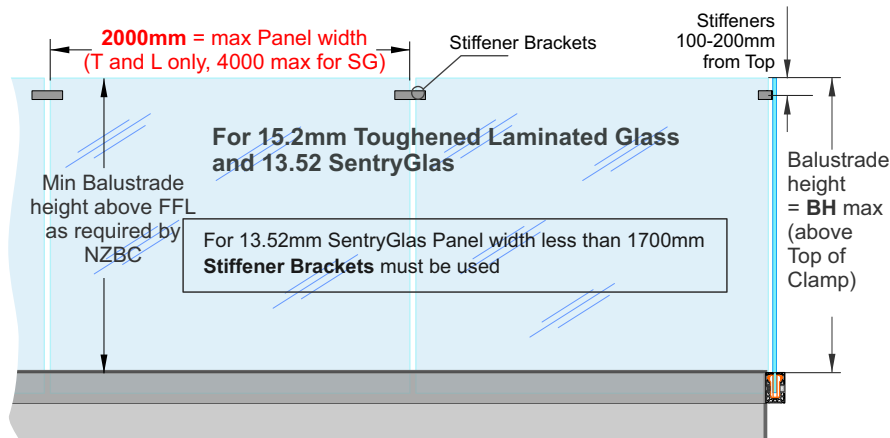

Exceeds the wind loading for all Wind Zones up to **and Including Extra High Wind Zone** as set out in NZS 3604:2011

Refer to the Stiffener Bracket pages for conformance to NZS 4223.3.2016.

PosiGlaze Balustrade System Side Fix + Stiffener Brackets

Glass must have a minimum strength of 100Mpa. Seen edges polished

Commercial Occupancy types B, E and C3, for
- 17.2mm Laminated Glass
- 17.52mm SentryGlas

Refer page, 'Allowable Heights for Side Fix Balustrade' for differing Wind Zones

See individual Mounting pages for construction options

Use 4 x Clamps per m

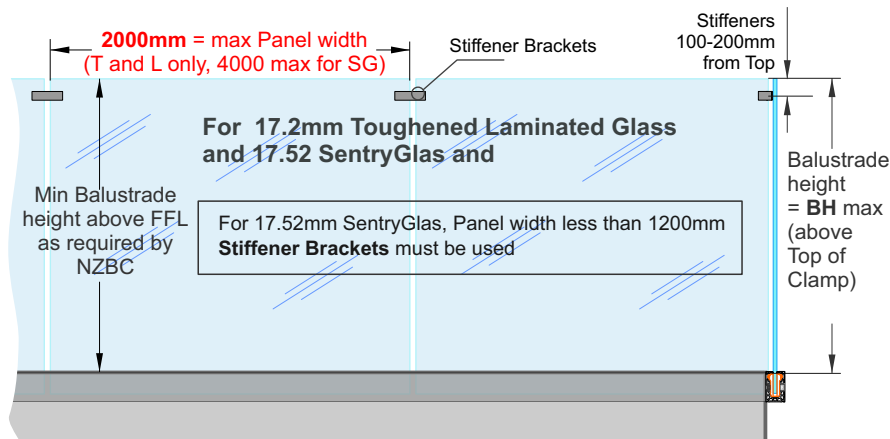

Exceeds the wind loading for all Wind Zones up to **and Including Extra High Wind Zone** as set out in NZS 3604:2011

Refer to the Stiffener Bracket pages for conformance to NZS 4223.3.2016.

PosiGlaze Balustrade System Side Fix + Stiffener Brackets

Glass must have a minimum strength of 100Mpa. Seen edges polished

Commercial Occupancy types B, E and C3, for
- 21.52mm SentryGlas

Commercial Occupancy types C1/C2 and D, for
- 21.52mm SentryGlas

Refer page, 'Allowable Heights for Side Fix Balustrade' for differing Wind Zones

See individual Mounting pages for construction options

Must use 5 x Clamps per m

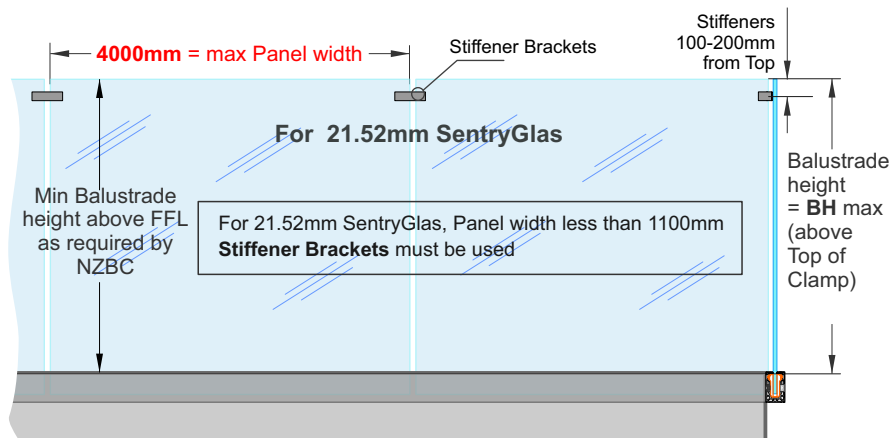

Applies to 21.52mm SentryGlas mounted to Steel or Concrete. Not to Timber.

Exceeds the wind loading for all Wind Zones up to **and Including Extra High Wind Zone** as set out in NZS 3604:2011

Refer to the Stiffener Bracket pages for conformance to NZS 4223.3.2016.



JURALCO

www.juralco.co.nz ph (09) 478 8018

Juralco Edgetec® PosiGlaze™ Balustrade System

Issue 10-25 v1

Page 6

**Juralco Edgetec® PosiGlaze™ Balustrade System
Typical Layouts - Pool Stairs/Steps - Side Fix**

Side Fix PosiGlaze
Pool Access **Stairs**

Important Note:
 - Up to and including Medium Wind Zone
 - Applies to Side Fix Posiglaze
 - Final Panel below Stairs must finish at BH 1200mm

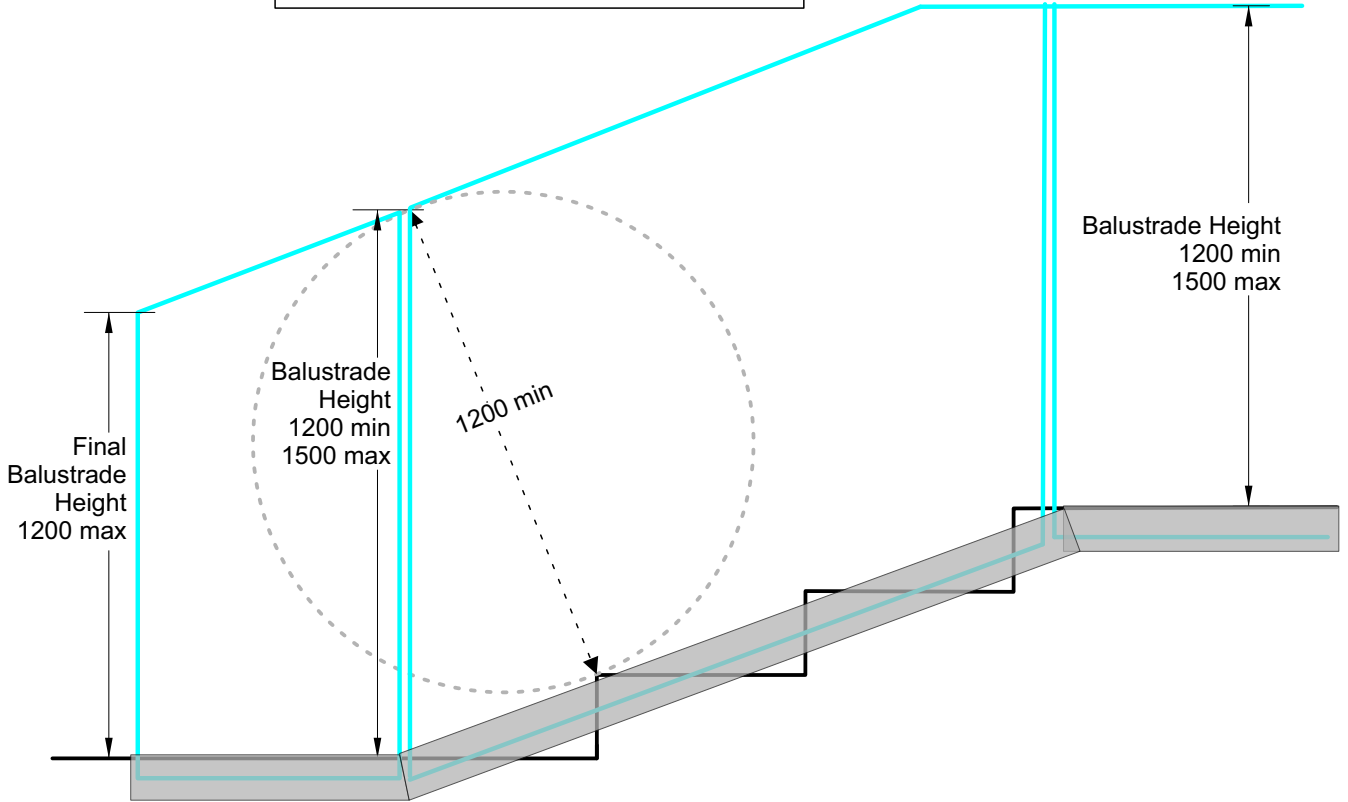

Side Fix PosiGlaze
Pool Access **Steps**

Important Note:
 - Up to and including Medium Wind Zone
 - Applies to Side Fix PosiGlaze
 - Final Panel below Step must finish at BH 1200mm

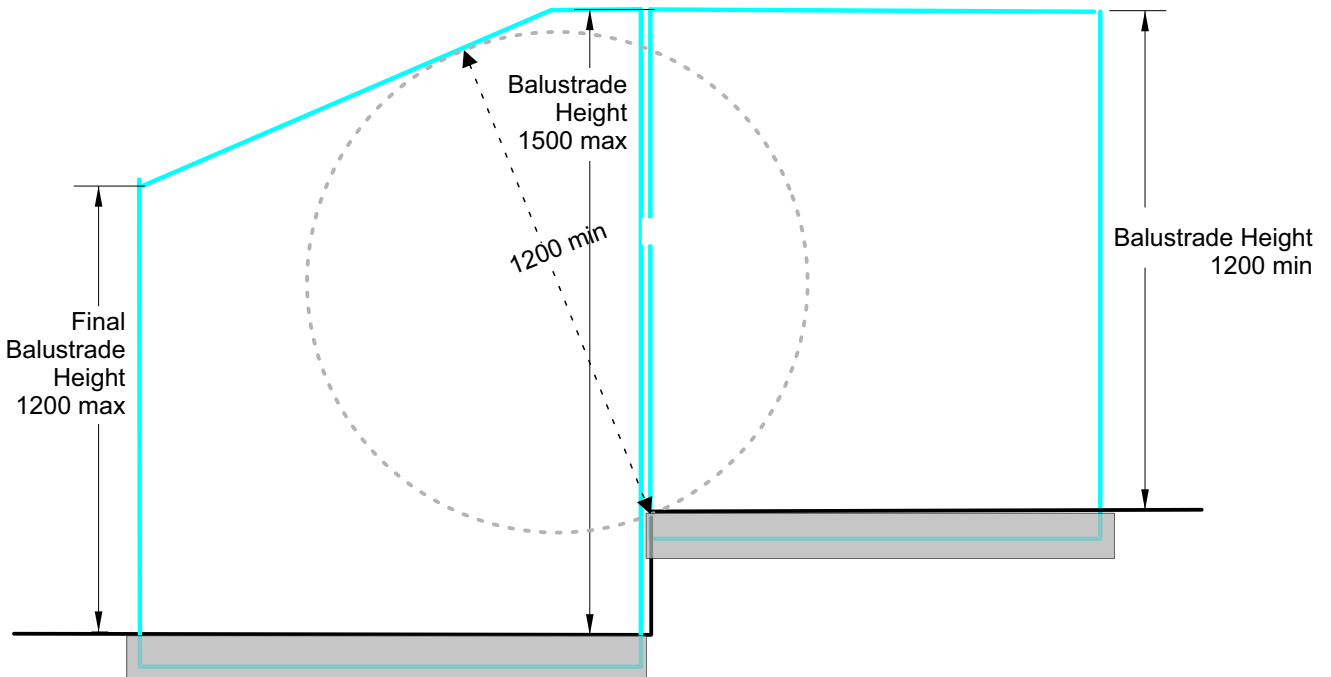

**Juralco Edgetec® PosiGlaze™ Balustrade System
Side Fix General**

Juralco PosiGlaze
Glass Balustrade
Side Fix
(15mm Glass Shown)

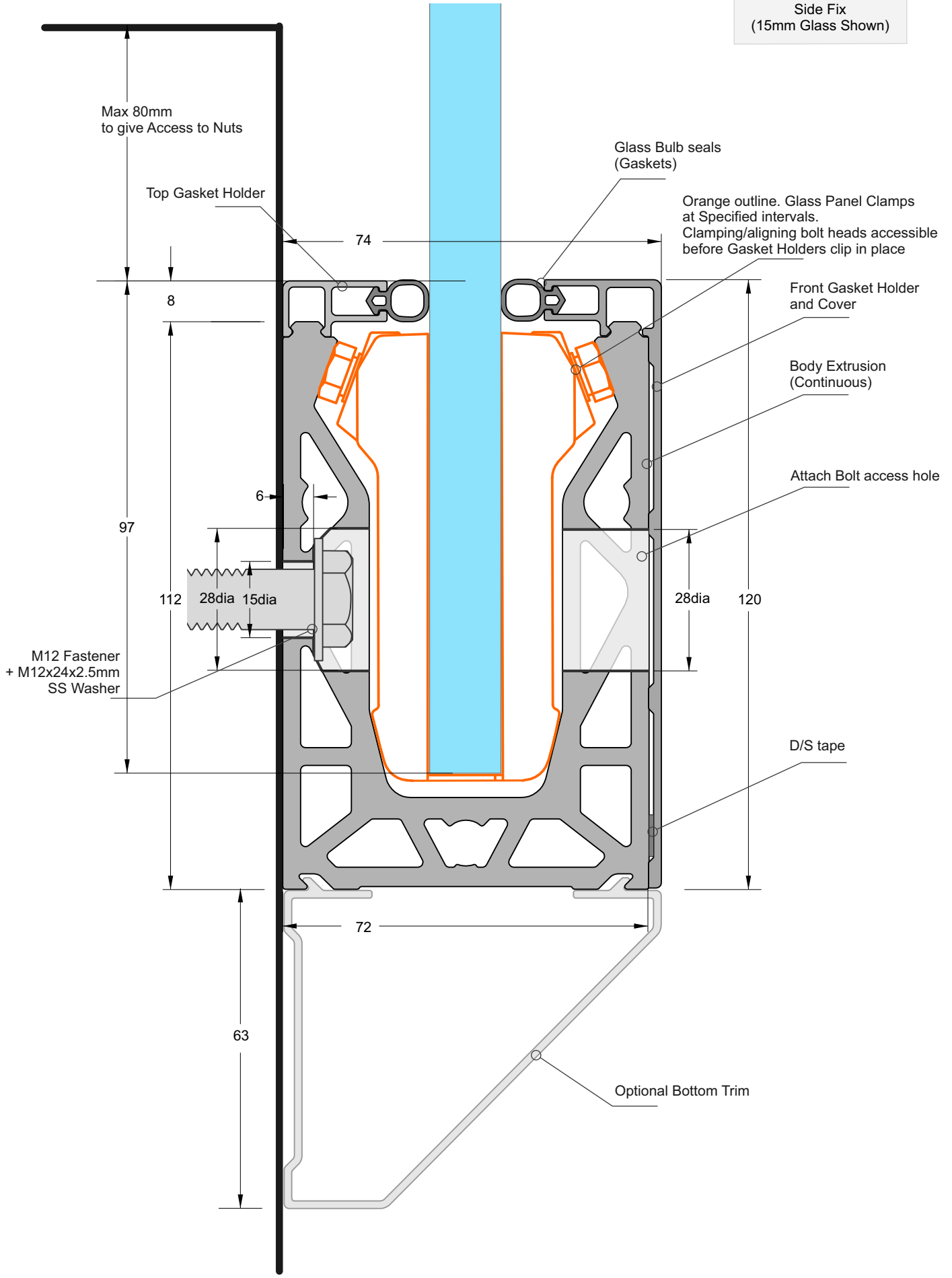

Juralco Edgetec® PosiGlaze™ Balustrade System Typical Stair Layout

PoziGlaze Balustrade Stairs, Side Fix

Stair structure to be designed by others to resist Balustrade actions as per NZS1170.1 Table 3.3

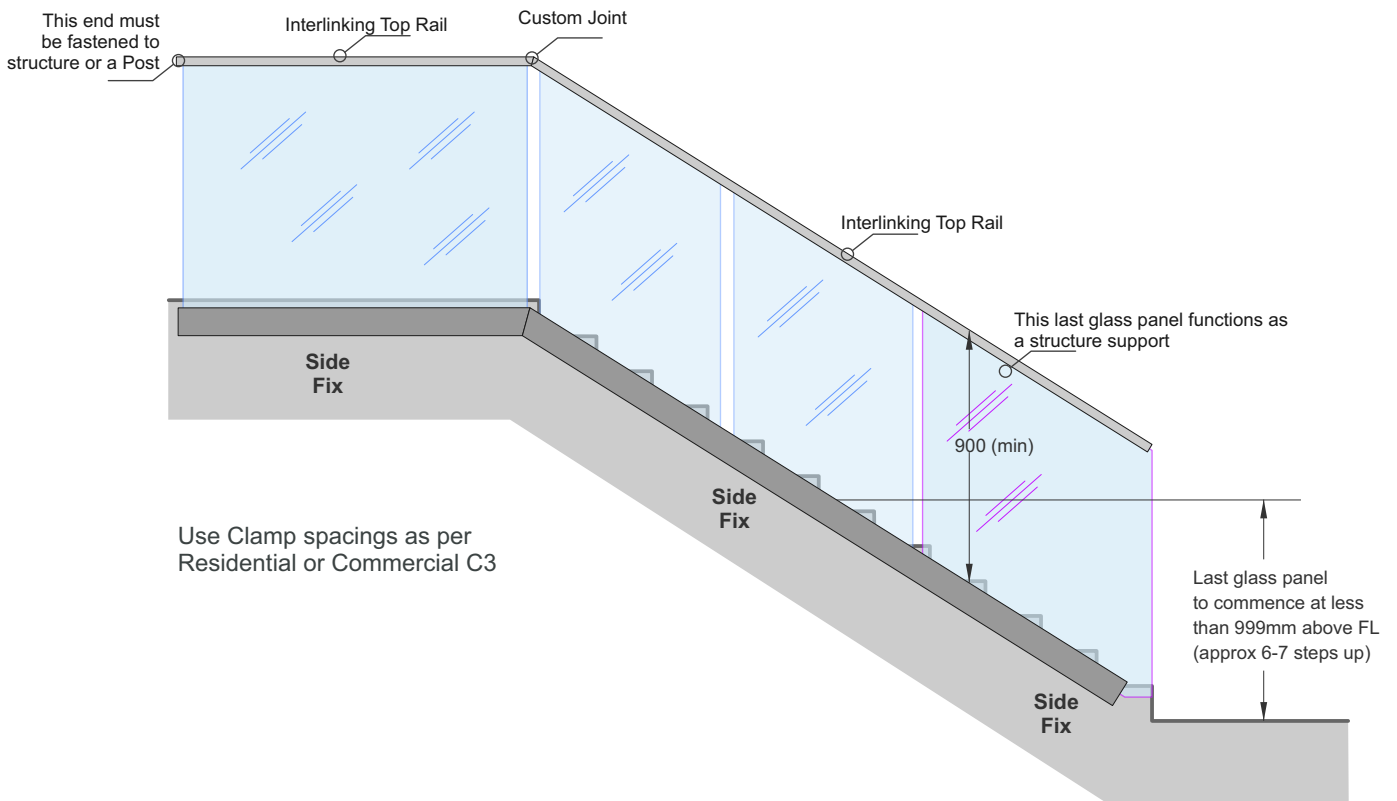

PoziGlaze Balustrade Side Fix only Stair Stringer Detail

Stair structure to be designed by others to resist Balustrade actions as per NZS1170.1 Table 3.3
For Internal use only, Residential Type A

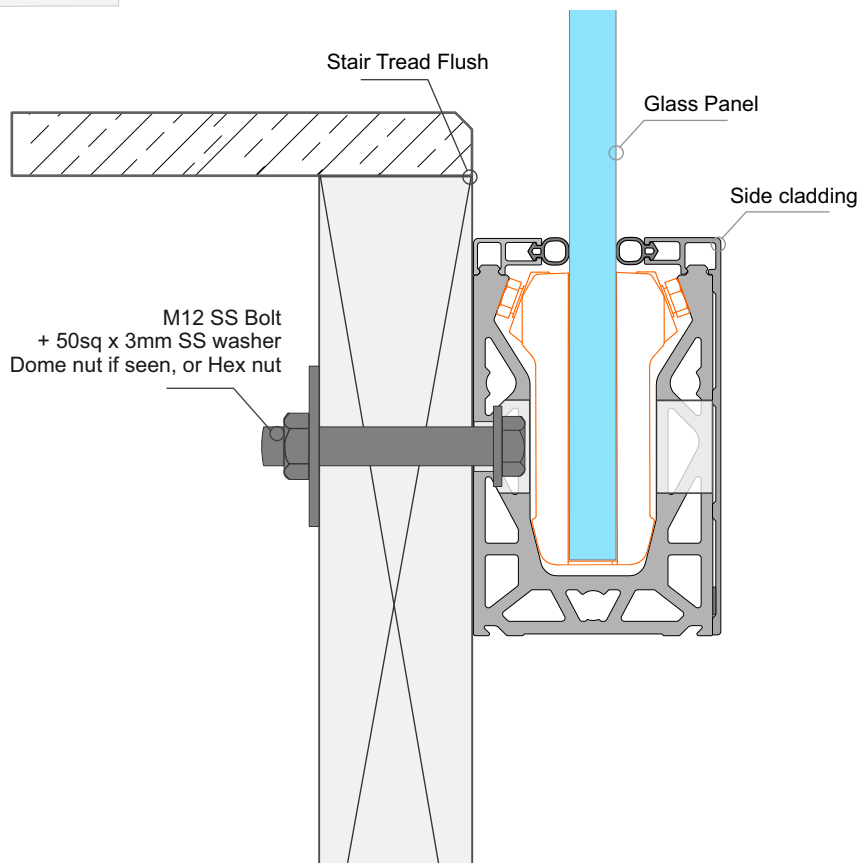

Juralco Edgetec® PosiGlaze™ Balustrade System

Extrusions, Components

Finishes:

BNAT = Brushed Natural Anodised, 20 micron

NAT - Natural Anodised 20 micron.

SCC = Duralloy Plus Powder coat

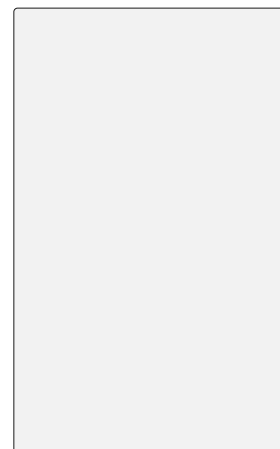
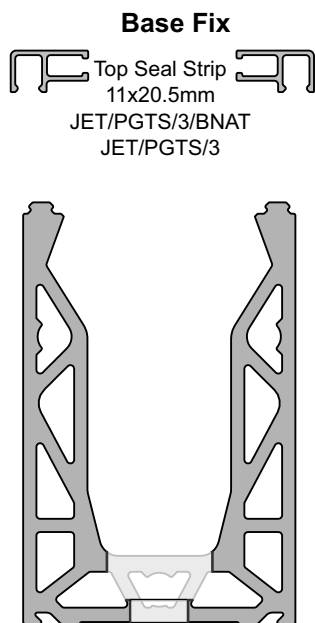
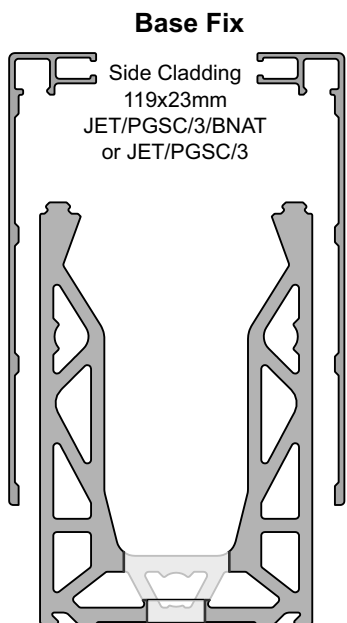

PosiGlaze Base Fix Channel x 3m
72x111.5mm. Predrilled @ 200mm crs
JET/PGB/3/BNAT
or JET/PGB/3/NAT

PosiGlaze Base Fix End Plates

Base fix 120mm x 72mm
JET/PGEPB/NAT or JET/PGEPB
(2 x Top seals)

Base fix 120mm x 77mm
JET/PGEPB2/NAT or JET/PGEPB2
(2 x Side Cladding)

Bottom Spacer Plates

Packers (height adjustment)
- Timber - Use 2 per layer, end to end to form 150mm long x 75mm wide
- Steel and Concrete, use one only 75mm sq

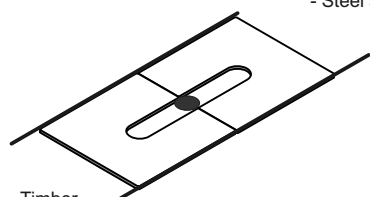

Timber
2 x 75 long x 75 wide

1mm thick Plate - Part No JET/IBT/BSP1

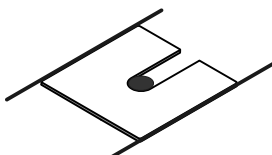

Steel and Concrete
1 x 75 long x 75 wide.
Insert then rotate 90 deg

5mm thick Plate - Part No JET/IBT/BSP5



Joining Dowels
Set of x2
JET/PGD



Top Seal Gasket
12, 15, 17.5mm Glass
JET/PGG/1217



PosiGlaze
10mm Spanner
JET/PGSP



Top Seal Gasket
19, 21.5mm Glass
JET/PGG/1921

Pressure Screw + Clamp Bar
M10x10, Special screw thread

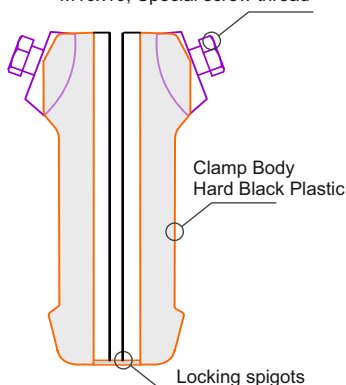

PosiGlaze Glass Clamp - Black

JET/PGC/12 12mm Toughened
JET/PGC/13.5 13.52mm SentryGlas
JET/PGC/15 15mm Toughened and 15.2mm Laminated
JET/PGC/17.5 17.2mm Laminated and 17.52mm SentryGlas
JET/PGC/21.5 21.52mm Glass SentryGlas

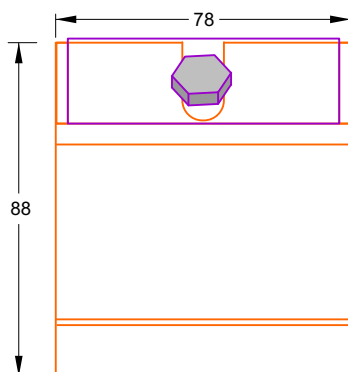

SIKA Supergrip
JESUPERGRIP30

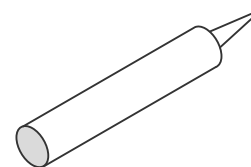

For All Coachscrews fixings

Rhodorsil V60 Clear Silicone
H/RTV419098

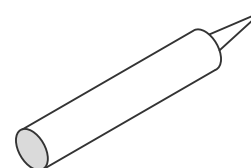

Construction Silicone

Juralco Edgetec® PosiGlaze™ Balustrade System

Side Fix

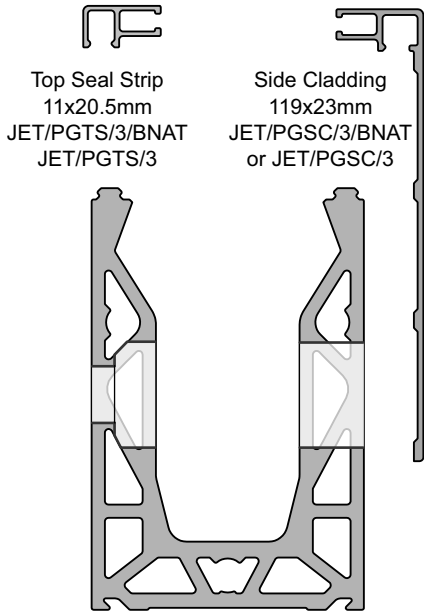

PosiGlaze Side Fix Channel x 3m
72mm x 111.5mm. Predrilled @ 200mm crs
JET/PGB/3/NAT

Extrusions, Components

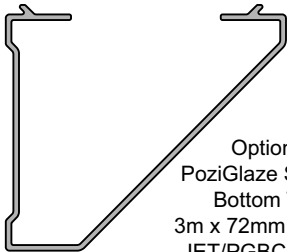

Joining Dowels
Set of x2
JET/PGD



PosiGlaze
10mm Spanner
JET/PGSP



Top Seal Gasket
12, 15, 17.5mm Glass
JET/PGG/1217



Top Seal Gasket
19, 21.5mm Glass
JET/PGG/1921

Rear Spacer Plate 15mm
Part No JET/IB/CSP/15

For use on
Timber Decks

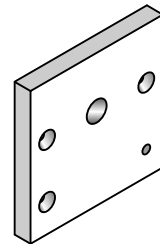

100 wide x 94 high x 15mm thick

Rear Spacer Plate
100 wide x 94 deep

Use only
if required

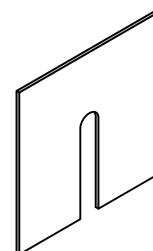

1mm thick Plate - Part No JET/IB/CSP/1.0
5mm thick Plate - Part No JET/IB/CSP/5.0

Pressure Screw + Clamp Bar
M10x10, Special screw thread

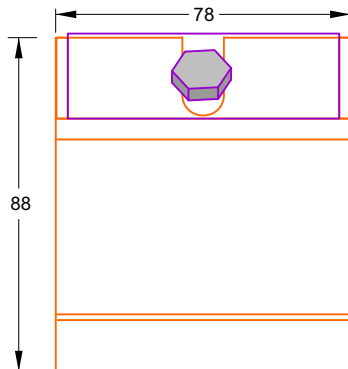
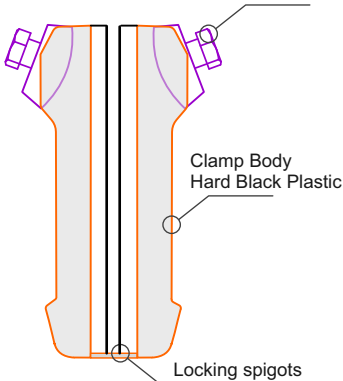

PosiGlaze Glass Clamp - Black

- JET/PGC/12 12mm Toughened
- JET/PGC/13.5 13.52mm SentryGlas
- JET/PGC/15 15mm Toughened and 15.2mm Laminated
- JET/PGC/17.5 17.2mm Laminated and 17.52mm SentryGlas
- JET/PGC/21.5 21.52mm Glass SentryGlas

Juralco Edgetec® PosiGlaze™ Balustrade System

Available as kits

Finishes:

BNAT = Brushed Natural Anodised, 20 micron

NAT - Natural Anodised 20 micron.

AMILL = Mill Finish

SCC = Duralloy Plus Powder coat

SIDE Fix Kit:

JET/PGS/KIT/BNAT. Brushed Nat Anodised Top seal and Side Cladding

JET/PGS/KIT/AMILL. Mill Top seal and Side Cladding

JET/PGS/KIT. Powdercoated Top seal and Side Cladding

For 12, 13.5, 15, 17.5 or 21.5mm Glass . **Specify Glass Thickness**

Includes 1 x 3m Length SIDE Fix Channel Pre-Drilled

1 x 3m Length Top Seal Strip BNAT, 1 x 3m Length Side Seal Strip

2 x Joining Dowels, 1 Set Of Clamp Kits (12 pieces), 2 x 3m Lengths of Gaskets,

1 x 10mm Spanner

Note: For 21.5 SentryGlas only, 1 Set Of Clamp Kits (15 pieces) supplied

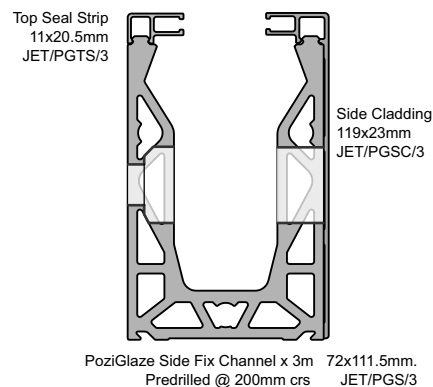

BASE Fix Kit:

JET/PGB/KIT/BNAT. Brushed Nat Anodised Top seals

For 12, 13.5, 15, 17.5 or 21.5mm Glass . **Specify Glass Thickness**

Includes 1 x 3m Length SIDE Fix Channel Pre-Drilled

1 x 3m Length Top Seal Strip BNAT, 1 x 3m Length Side Seal Strip

2 x Joining Dowels, 1 Set Of Clamp Kits (12 pieces), 2 x 3m Lengths of Gaskets,

1 x 10mm Spanner

Note: For 21.5 SentryGlas only, 1 Set Of Clamp Kits (15 pieces) supplied

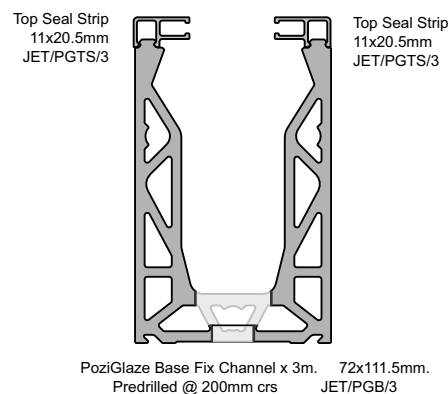

BASE Fix Kit:

JET/PGB/KIT/AMILL. Mill Side Claddings

JET/PGB/KIT. Powdercoated Side Claddings

For 12, 13.5, 15, 17.5 or 21.5mm Glass . **Specify Glass Thickness**

Includes 1 x 3m Length SIDE Fix Channel Pre-Drilled

1 x 3m Length Top Seal Strip BNAT, 1 x 3m Length Side Seal Strip

2 x Joining Dowels, 1 Set Of Clamp Kits (12 pieces), 2 x 3m Lengths of Gaskets,

1 x 10mm Spanner

Note: For 21.5 SentryGlas only, 1 Set Of Clamp Kits (15 pieces) supplied

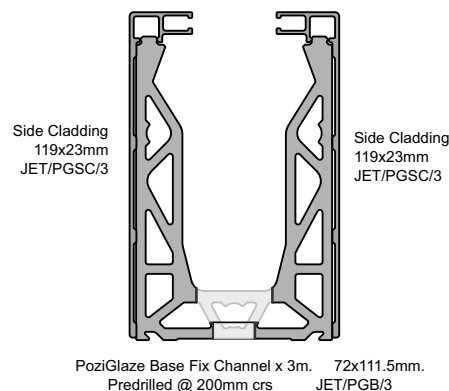

Allowable Heights for Side Fix Balustrade

Glass Thickness, Type	Wind Zone	Barrier Height, mm (max above Clamp)	Fix attach centres, mm
Residential Occupancy A, A Other and C3 only			
12mm Toughened @4xPosiglaze Clamps/m	High	1300	400
	Very High	1200	200
	Extra High	1050	200
13.52mm SentryGlas @4xPosiglaze Clamps/m	High	1300 ^{*NOTE 3}	400
	Very High	1200 ^{*NOTE 3}	200
	Extra High	1050	200
15.2mm Laminated @4xPosiglaze Clamps/m	High	1300	400
	Very High	1200	200
	Extra High	1050	200
Commercial Occupancy B, E and C3 only			
15mm Toughened @4xPosiglaze Clamps/m	High	1500	200
	Very High	1300	200
	Extra High	1200	200
17.2mm Laminated @4xPosiglaze Clamps/m	High	1500	200
	Very High	1300	200
	Extra High	1200	200
17.52mm SentryGlas @4xPosiglaze Clamps/m	High	1500 ^{*NOTE 3}	200
	Very High	1300 ^{*NOTE 3}	200
	Extra High	1200 ^{*NOTE 3}	200
21.52mm SentryGlas (Mounting to Steel or Concrete only, not Timber) @5xPosiglaze Clamps/m	High	1800 ^{*NOTE 3}	200
	Very High	1600 ^{*NOTE 3}	200
	Extra High	1400 ^{*NOTE 3}	200

Commercial Occupancy C1/C2, D only			
Glass Thickness, Type	Wind Zone	Barrier Height, mm (max above Clamp)	Fix attach centres, mm
21.52mm SentryGlas (Mounting to Steel or Concrete only, not Timber) @5xPosiglaze Clamps/m	Extra High	1100	200

Notes.

Note 1: For Toughened Glass Interlinking Rails or Handrails MUST be used. Not for use with Stiffener Brackets

Note 2: For Laminated Glass Interlinking Rails, Handrails or Stiffener Brackets may be used.

Note 3: SentryGlas Interlinking Rails, Handrails or Stiffener Brackets may be used, but see table below.

For SentryGlas, Stiffener Brackets MUST be used above these Heights or below these Widths

Glass Thickness, Type	Barrier Height, mm (max above Clamp)	Panel Width, mm (minimum)
13.52mm SentryGlas	1050	1700mm
17.52mm SentryGlas	1250	1200mm
21.52mm SentryGlas	1250	1100mm

For Pool Fencing only - Side Fix only

Applies to Pool Fences not protecting a fall of 1.0m or more

Wind Zone up to and Including	Heights for, Glass 12mm Toughened	Heights for, Glass 15mm Toughened	Fix attach crs, mm
Medium	1500mm	1700mm	200mm
High	1350mm	1550mm	200mm
Very High	1200mm	1350mm	200mm
Extra High	NA	1250mm	200mm

Layered Glasses, Construction

Laminated Glass Layers and Thickness Orientation

Glass Thickness (mm)	Inner Layer of Glass thickness (mm) Deckside	Interlayer thickness (mm) and Type	Outer Layer Glass thickness (mm)
15.2	6	1.2 EVA	8
17.2	8	1.2 EVA	8

SentryGlas® Glass Layers and Thickness Orientation

Glass Thickness (mm)	Inner Layer of Glass thickness (mm) Deckside	Interlayer thickness (mm) and Type	Outer Layer Glass thickness (mm)
13.52	6	1.52 SG	6
17.52	8	1.52 SG	8
21.52	10	1.52 SG	10



Max Design Loads - all for Side Fix only

For use by Project Engineers to develop Site Specific designs

PosiGlaze Side Fix only				Max Design loads to substructure (per fixing point)		Wind Pressures (ULS to SLS Factor 0.75)		
Glass Type & Thickness (mm)	Occupancy	Max Height (mm)	Fixing Centres (mm)	T* (kN)	V*(kN)	Wind Zones	ULS	SLS
12T, 13.52SG, 15.2L	Residential Occupancy A, A Other and C3	1300	400	11.78	0.5	High	1.69	1.27
		1200	200	9.9	0.47	Very High	2.2	1.65
		1050	200	8.78	0.41	Extra High	2.69	2.02
15T, 17.52SG, 17.2L	Commercial Occupancy B, E and C3	1500	200	9.9	0.67	High	1.67	1.25
		1300	200	9.9	0.58	Very High	2.16	1.64
		1200	200	9.9	0.54	Extra High	2.66	2
21.52SG	Commercial Occupancy B, E and C3	1800	200	13.49	0.99	High	1.74	1.31
		1600	200	13.98	0.88	Very High	2.28	1.71
		1400	200	13.2	0.77	Extra High	2.79	2.09
	Commercial C1/C2	1100	200	11.45	0.6	Extra High	2.84	2.13
12T, 15T	Pool Fencing Only	1250	200	10.7	0.48	Extra High	2.65	1.99

**Notes : 1 - Refer previous page for additional information
2 - Glass type T= Toughened, L = Laminated, SG = SentryGlas**

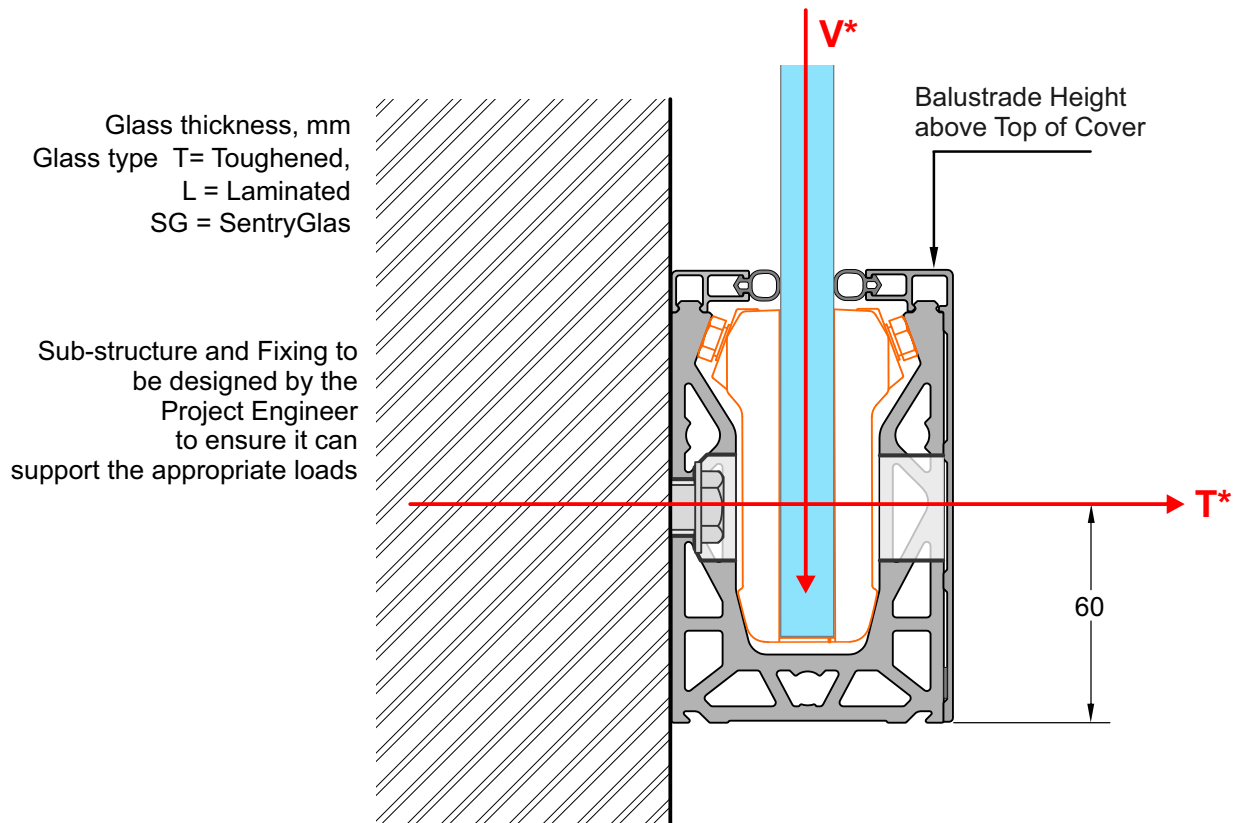

Juralco Edgetec® PosiGlaze™ Balustrade System Typical Fixing - Side Fix

Typical SIDE Fix to Timber - M12 SS Coachscrew

Complies with NZS3604:2011 - Double Boundary Joists

**Maximum Balustrade Heights.
Up to and including
Extra High Wind Zone.**

Residential Occupancy A, A Other and C3		Commercial Occupancy B, E and C3	
Glass Thickness, Type	Balustrade Height (max)	Glass Thickness, Type	Balustrade Height (max)
12 T	1050	15 T	1200
13.52 SG	1050	17.2 L	1200
15.2 L	1050	17.52SG	1200

Glass Thickness/Height/Type for this mounting type only

General Notes:

- Refer page, 'Allowable Heights for Side Fix Balustrade' for other Wind Zones
 - For fixing to substrate crs.
 - Stiffener Brkts and
 - Swimming Pool fences
- Glass thickness, mm.
Glass type T= Toughened, L = Laminated, SG = SentryGlas
- All measurements mm
- Use 4x Posiglaze Clamps/m

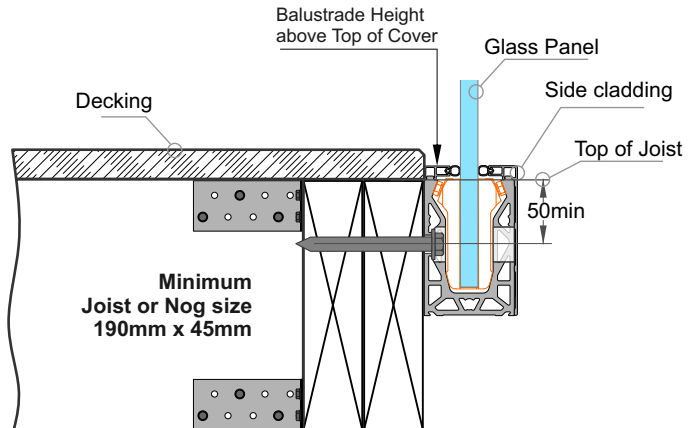

Important Installation notes:

- The Project Engineer must ensure the structure can support the appropriate loads
- Substructure shown indicatively only. Timber SG8 minimum strength
- Coachscrew 90mm min engagement into joists, predrill 6mm holes.
- Bond all Screws with SIKA Supergrip30 to full depth
- Use Threadlok on all Clamp Pressure Screws
- All Fixings must be Stainless steel

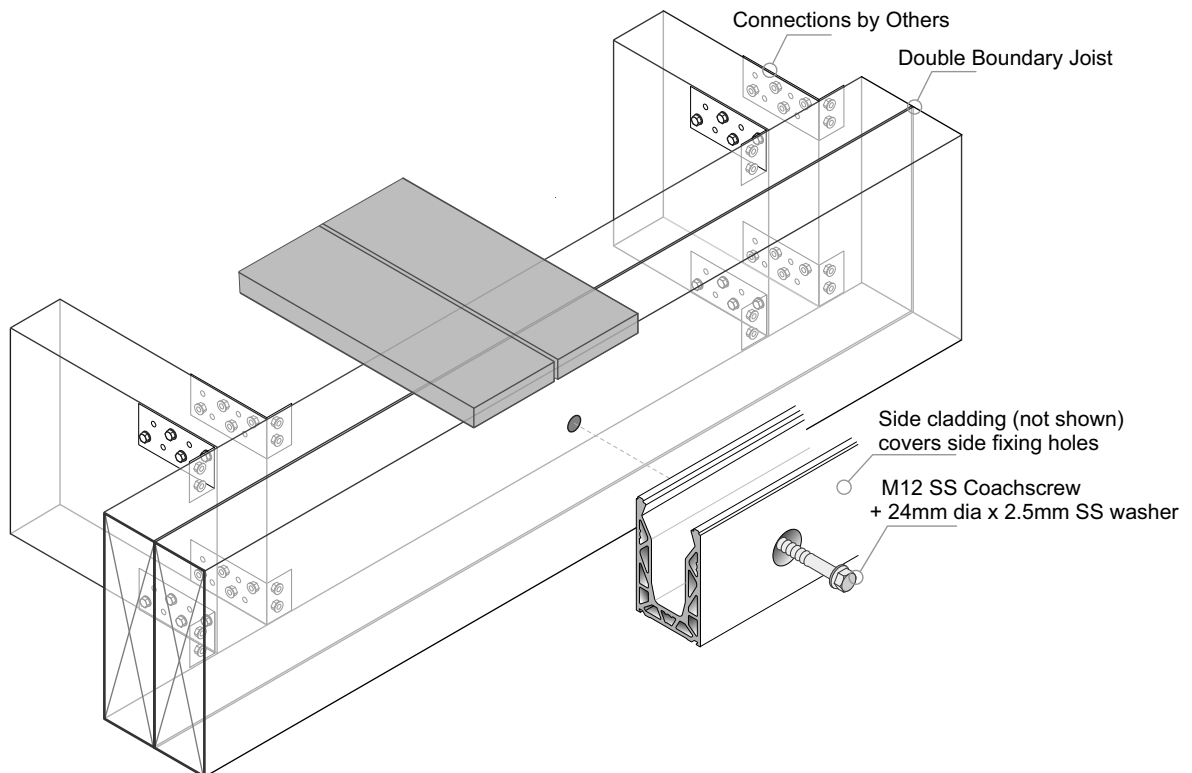

Juralco Edgetec® PosiGlaze™ Balustrade System Typical Fixing - Side Fix

Typical SIDE Fix to Timber - M12 SS, Bolt or Threaded Rod

**Maximum Balustrade Heights.
Up to and including
Extra High Wind Zone.**

Residential Occupancy A, A Other and C3		Commercial Occupancy B, E and C3	
Glass Thickness, Type	Balustrade Height (max)	Glass Thickness, Type	Balustrade Height (max)
12 T	1050	15 T	1200
13.52 SG	1050	17.2 L	1200
15.2 L	1050	17.52SG	1200

Glass Thickness/Height/Type for this mounting type only

General Notes:

- 1 - Refer page, 'Allowable Heights for Side Fix Balustrade' for other Wind Zones
 - For fixing to substrate crs.
 - Stiffener Brkts and
 - Swimming Pool fences
- 2 - Glass thickness, mm.
Glass type T= Toughened, L = Laminated, SG = SentryGlas
- 3 - All measurements mm
- 4 - Use 4x Posiglaze Clamps/m

Complies with NZS3604:2011 - Double Boundary Joists

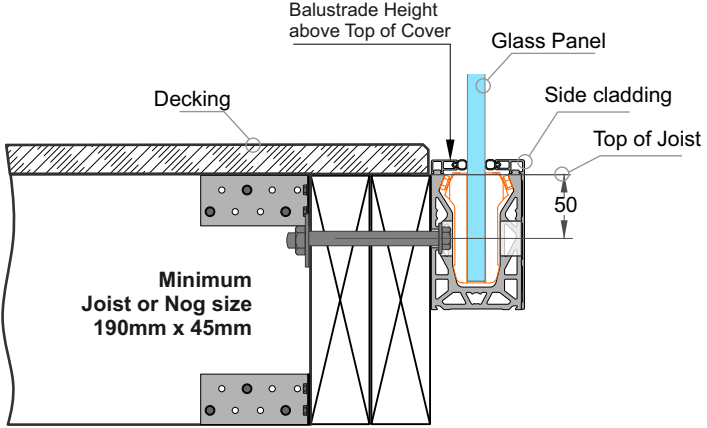

Important Installation notes:

- 1 - The Project Engineer must ensure the structure can support the appropriate loads
- 2 - Substructure shown indicatively only. Timber SG8 minimum strength
- 3 - Use Threadlok on all Clamp Pressure Screws
- 4 - All Fixings must be Stainless steel

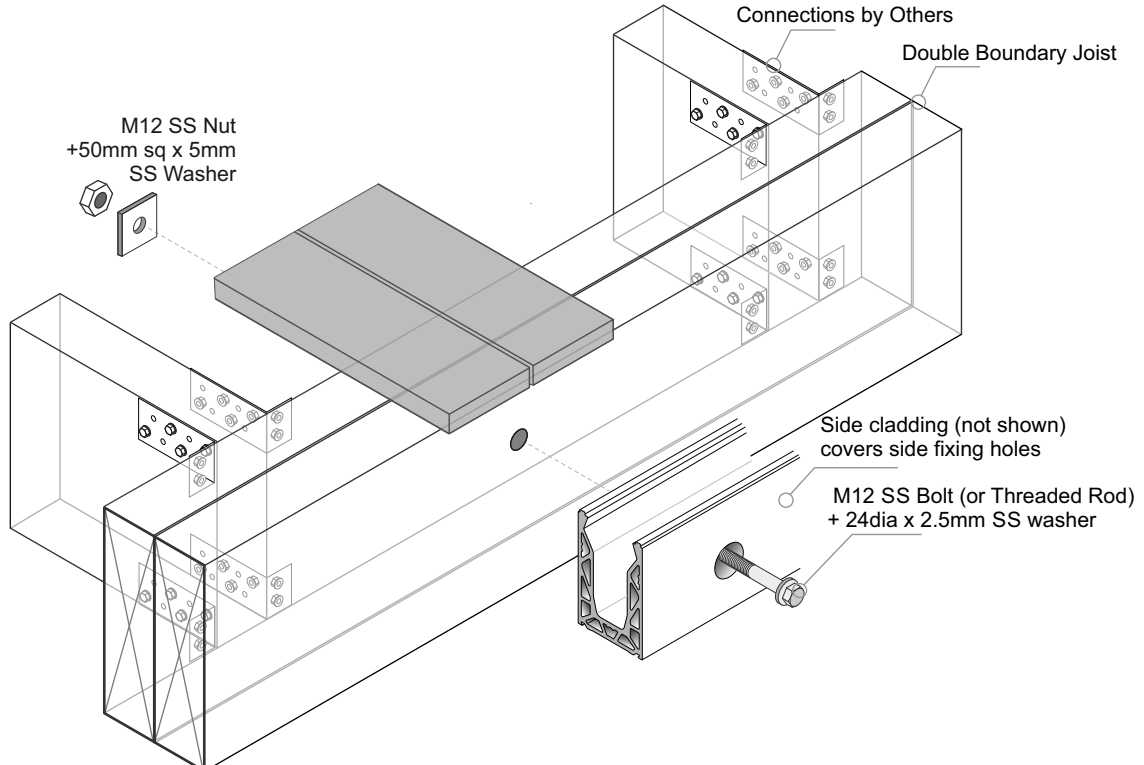

Juralco Edgetec® PosiGlaze™ Balustrade System Typical Fixing - Side Fix

Typical Hidden SIDE Fix to Timber - M12 SS Coachscrew

Complies with NZS3604:2011 - Double Boundary Joists

**Maximum Balustrade Heights.
Up to and including
Extra High Wind Zone.**

Residential Occupancy A, A Other and C3		Commercial Occupancy B, E and C3	
Glass Thickness, Type	Balustrade Height (max)	Glass Thickness, Type	Balustrade Height (max)
12 T	1050	15 T	1200
13.52 SG	1050	17.2 L	1200
15.2 L	1050	17.52SG	1200

Glass Thickness/Height/Type for this mounting type only

General Notes:

- 1 - Refer page, 'Allowable Heights for Side Fix Balustrade' for other Wind Zones
 - For fixing to substrate crs.
 - Stiffener Brkts and
 - Swimming Pool fences
- 2 - Glass thickness, mm.
Glass type T= Toughened, L = Laminated, SG = SentryGlas
- 3 - All measurements mm
- 4 - Use 4x Posiglaze Clamps/m

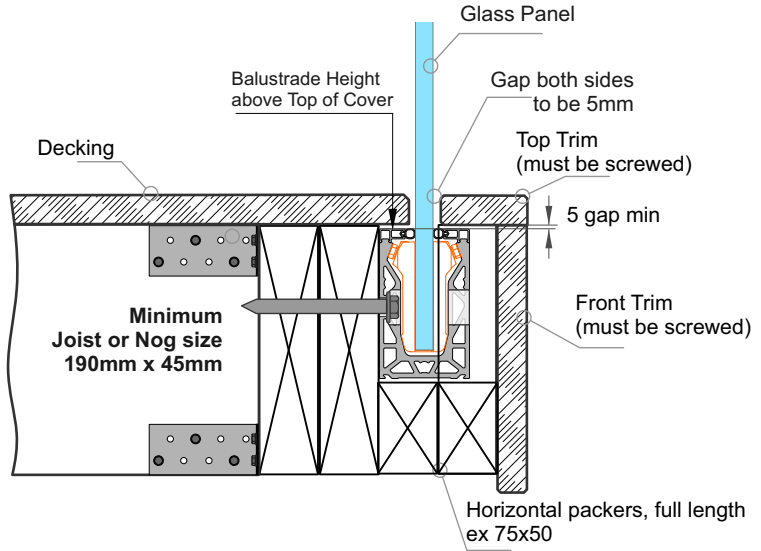

Important Installation notes:

- 1 - The Project Engineer must ensure the structure can support the appropriate loads
- 2 - Substructure shown indicatively only. Timber SG8 minimum strength
- 3 - Coachscrew 90mm min engagement into joists, predrill 6mm holes.
- 4 - Bond all Screws with SIKA Supergrip30 to full depth
- 5 - All Fixings must be Stainless steel

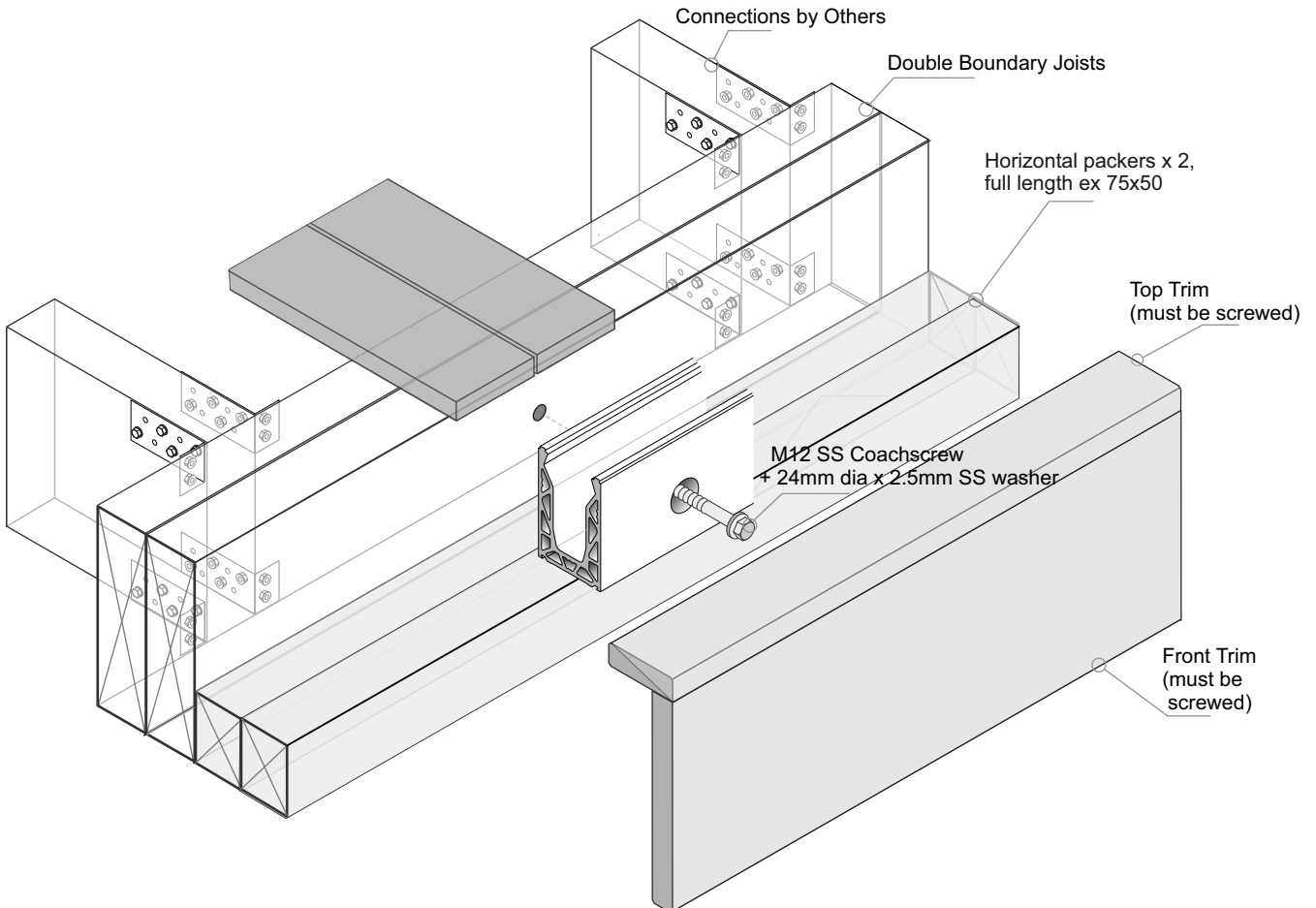

Juralco Edgetec® PosiGlaze™ Balustrade System Typical Fixing - Side Fix

Typical SIDE Fix through a cavity into Timber - M12 SS Coachscrew

Complies with NZS3604:2011 - Double Boundary Joists

**Maximum Balustrade Heights.
Up to and including
Extra High Wind Zone.**

Residential Occupancy A, A Other and C3		Commercial Occupancy B, E and C3	
Glass Thickness, Type	Balustrade Height (max)	Glass Thickness, Type	Balustrade Height (max)
12 T	1050	15 T	1200
13.52 SG	1050	17.2 L	1200
15.2 L	1050	17.52SG	1200

Glass Thickness/Height/Type for this mounting type only

General Notes:

- 1 - Refer page, 'Allowable Heights for Side Fix Balustrade' for other Wind Zones
 - For fixing to substrate crs.
 - Stiffener Brkts and
 - Swimming Pool fences
- 2 - Glass thickness, mm.
 - Glass type T= Toughened, L = Laminated, SG = SentryGlas
- 3 - All measurements mm
- 4 - Use 4x Posiglaze Clamps/m

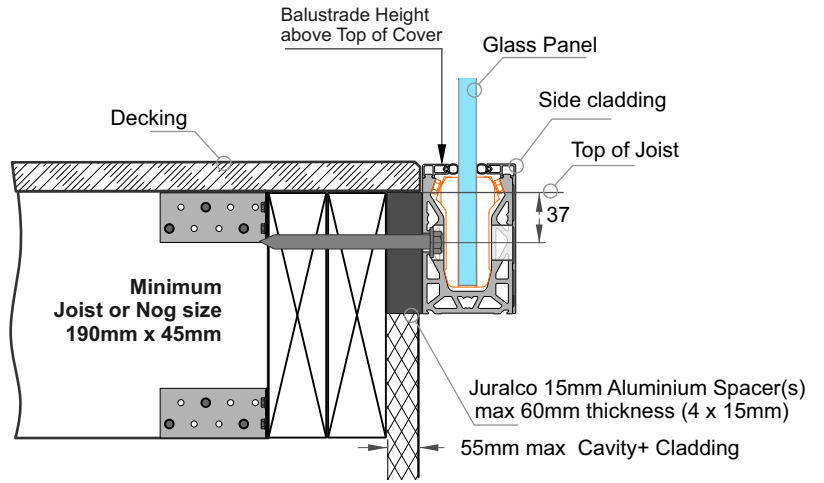

Important Installation notes:

- 1 - The Project Engineer must ensure the structure can support the appropriate loads
- 2 - Substructure shown indicatively only. Timber SG8 minimum strength
- 3 - Coachscrew 90mm min engagement into joists, predrill 6mm holes.
- 4 - Bond all Screws with SIKA Supergrip30 to full depth
- 5 - Use Threadlok on all Clamp Pressure Screws
- 6 - All Fixings must be Stainless steel

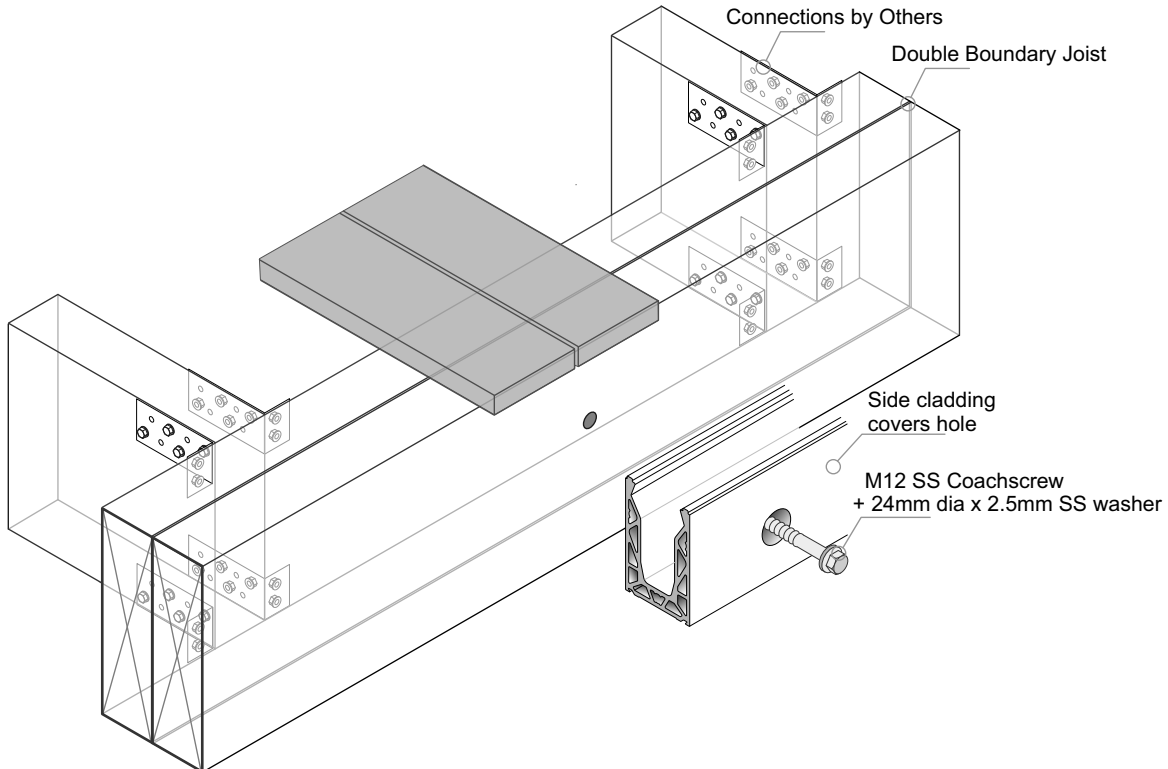

Juralco Edgetec® PosiGlaze™ Balustrade System Typical Fixing - Side Fix

Typical SIDE Fix through a Cavity into Timber - M12 SS, Bolt or Threaded Rod

**Maximum Balustrade Heights.
Up to and including
Extra High Wind Zone.**

Residential Occupancy A, A Other and C3	Commercial Occupancy B, E and C3
--	-------------------------------------

Glass Thickness, Type	Balustrade Height (max)	Glass Thickness, Type	Balustrade Height (max)
12 T	1050	15 T	1200
13.52 SG	1050	17.2 L	1200
15.2 L	1050	17.52SG	1200

Glass Thickness/Height/Type for this mounting type only

General Notes:

- 1 - Refer page, 'Allowable Heights for Side Fix Balustrade' for other Wind Zones
 - For fixing to substrate crs.
 - Stiffener Brkts and
 - Swimming Pool fences
- 2 - Glass thickness, mm.
 - Glass type T= Toughened, L = Laminated, SG = SentryGlas
- 3 - All measurements mm
- 4 - Use 4x Posiglaze Clamps/m

Complies with NZS3604:2011 - Double Boundary Joists

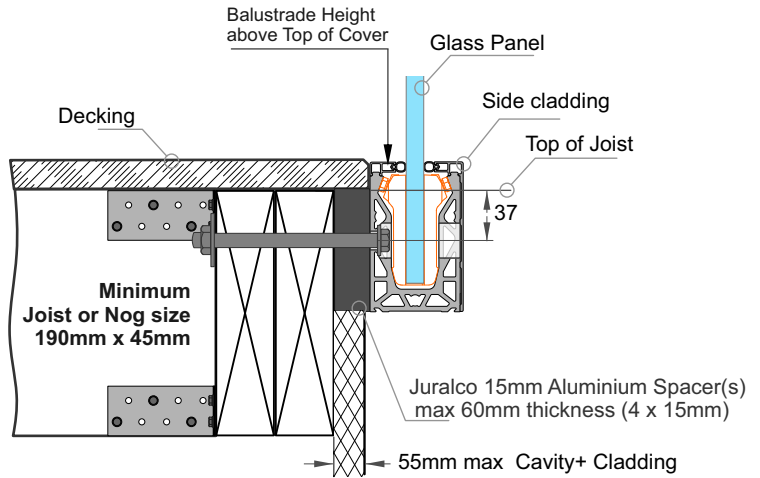

Important Installation notes:

- 1 - The Project Engineer must ensure the structure can support the appropriate loads
- 2 - Substructure shown indicatively only. Timber SG8 minimum strength
- 3 - Use Threadlok on all Clamp Pressure Screws
- 4 - All Fixings must be Stainless steel

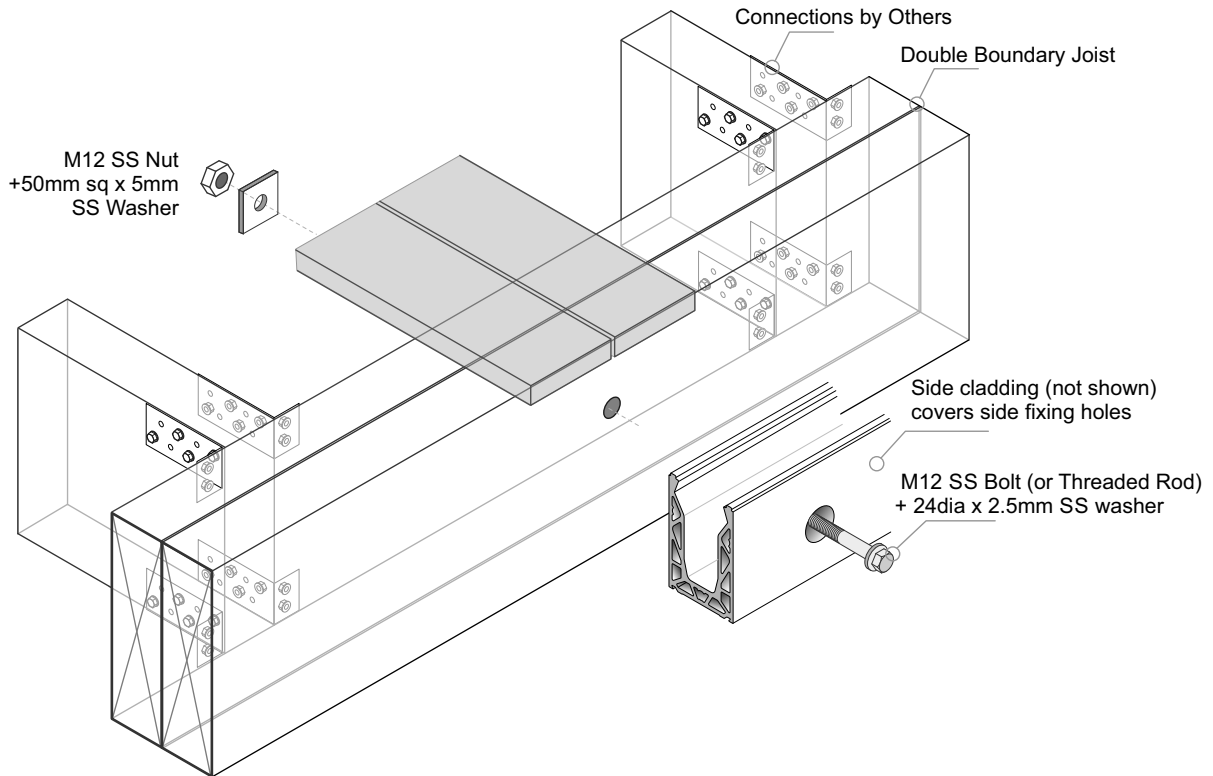

Juralco Edgetec® PosiGlaze™ Balustrade System Typical Fixing - Side Fix

Typical SIDE Fix to Steel - M12 SS, Bolt or Threaded Rod

**Maximum Balustrade Heights.
Up to and including Extra High Wind Zone.**

Residential Occupancy A, A Other and C3		Commercial Occupancy B, E and C3		Commercial Occupancy C1/C2 and D	
Glass Thickness, Type	Balustrade Height (max)	Glass Thickness, Type	Balustrade Height (max)	Glass Thickness, Type	Balustrade Height (max)
12 T	1050	15 T	1200	21.52SG	1100
13.52 SG	1050	17.2 L	1200		
15.2 L	1050	17.52SG	1200		
		21.52SG	1400		

Glass Thickness/Height/Type for this mounting only

General Notes:

- 1 - Refer page 'Allowable Heights for Side Fix Balustrade' for other Wind Zones
 - For fixing to substrate crs.
 - Stiffener Brkts and
 - Swimming Pool fences
- 2 - Glass thickness, mm.
Glass type T= Toughened, L = Laminated, SG = SentryGlas
- 3 - All measurements mm
- 4 - Use 4x Posiglaze Clamps/m except 21.52SG @ 5 Clamps/m

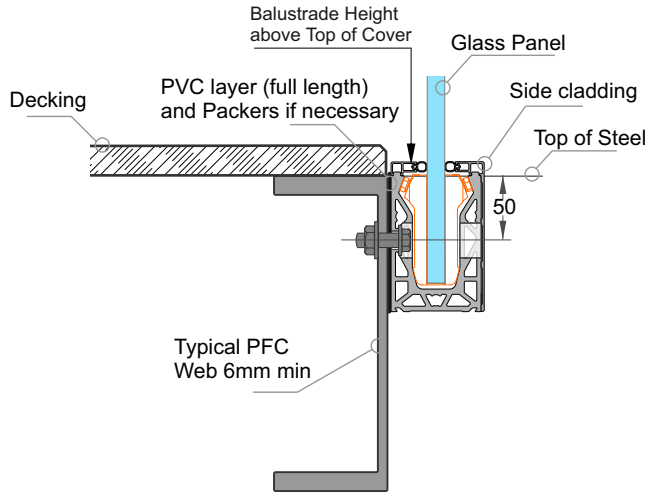

- Important Installation notes:**
- 1 - The Project Engineer must ensure the structure can support the appropriate loads
 - 2 - Substructure shown indicatively only
 - 3 - An PVC tape layer must be placed between the Channel and Steel
 - 4 - Use Threadlok on all Clamp Pressure Screws
 - 5 - All fixings must be Stainless Steel

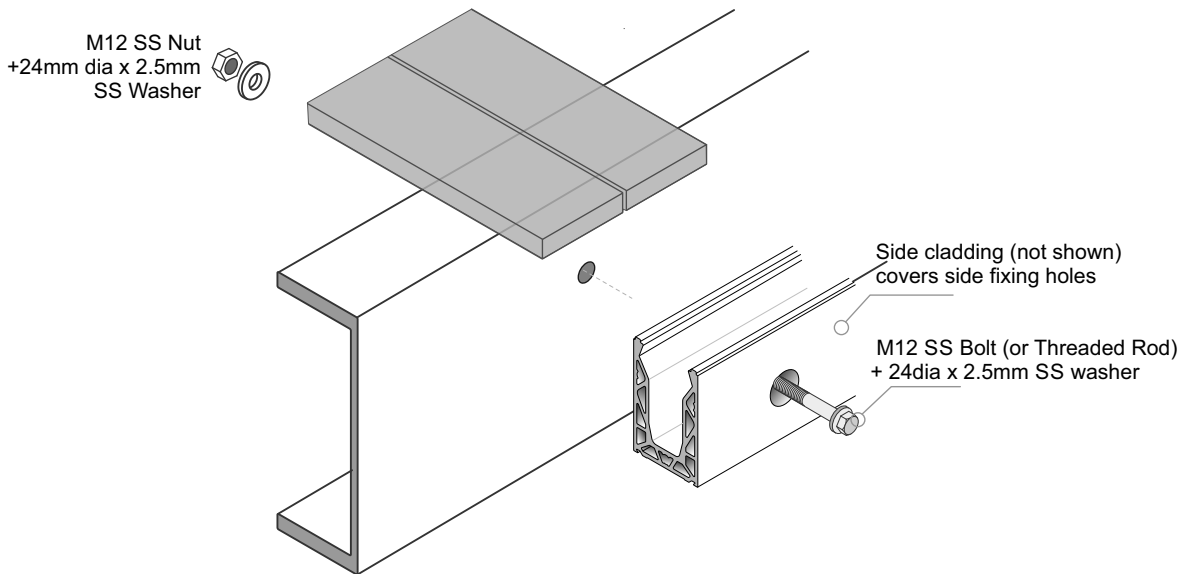

Juralco Edgetec® PosiGlaze™ Balustrade System Typical Fixing - Side Fix

Typical SIDE Fix to Steel, Wooden Packers - M12 SS, Bolt or Threaded Rod

**Maximum Balustrade Heights.
Up to and including Extra High Wind Zone.**

Residential Occupancy A, A Other and C3		Commercial Occupancy B, E and C3		Commercial Occupancy C1/C2 and D	
Glass Thickness, Type	Balustrade Height (max)	Glass Thickness, Type	Balustrade Height (max)	Glass Thickness, Type	Balustrade Height (max)
12 T	1050	15 T	1200	21.52SG	1100
13.52 SG	1050	17.2 L	1200		
15.2 L	1050	17.52SG	1200		
		21.52SG	1400		

Glass Thickness/Height/Type for this mounting only

General Notes:

- 1 - Refer page, 'Allowable Heights for Side Fix Balustrade' for other Wind Zones
 - For fixing to substrate crs.
 - Stiffener Brkts and
 - Swimming Pool fences
- 2 - Glass thickness, mm.
Glass type T= Toughened, L = Laminated, SG = SentryGlas
- 3 - All measurements mm
- 4 - Use 4x Posiglaze Clamps/m except 21.52SG @ 5 Clamps/m

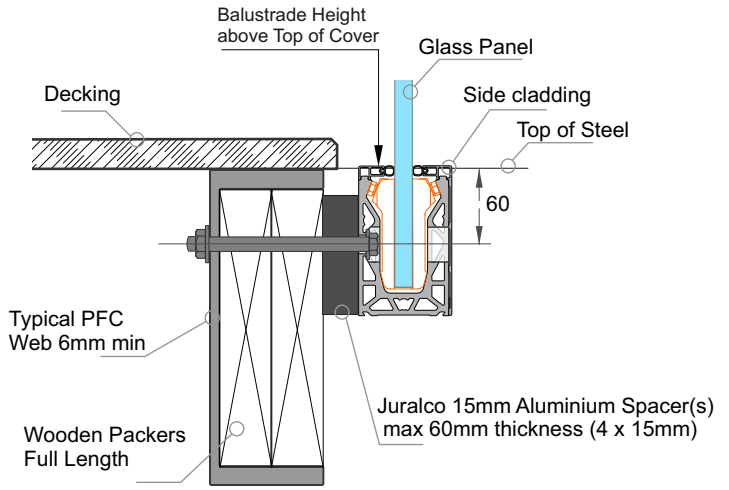

Important Installation notes:

- 1 - The Project Engineer must ensure the structure can support the appropriate loads
- 2 - Substructure shown indicatively only. Timber SG8 minimum strength
- 3 - Use Threadlok on all Clamp Pressure Screws
- 4 - All Fixings must be Stainless steel

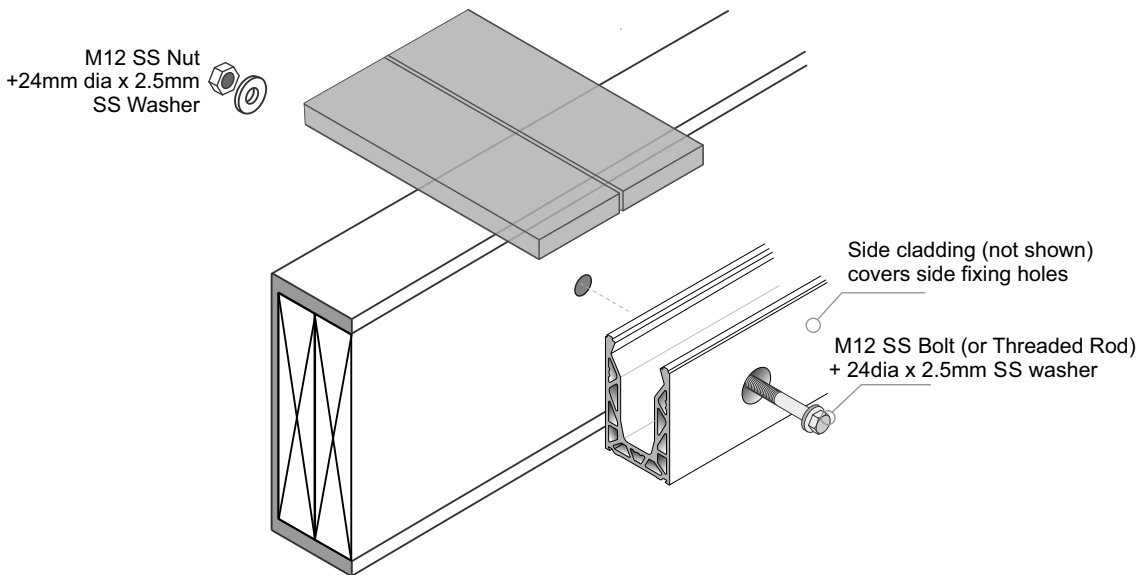

Juralco Edgetec® PosiGlaze™ Balustrade System Typical Fixing - Side Fix

Typical SIDE Fix to Steel, Wooden Packers - M12 SS, Bolt or Threaded Rod

**Maximum Balustrade Heights.
Up to and including Extra High Wind Zone.**

Residential Occupancy A, A Other and C3		Commercial Occupancy B, E and C3		Commercial Occupancy C1/C2 and D	
Glass Thickness, Type	Balustrade Height (max)	Glass Thickness, Type	Balustrade Height (max)	Glass Thickness, Type	Balustrade Height (max)
12 T	1050	15 T	1200	21.52SG	1100
13.52 SG	1050	17.2 L	1200		
15.2 L	1050	17.52SG	1200		
		21.52SG	1400		

Glass Thickness/Height/Type for this mounting only

General Notes:

- 1 - Refer page, 'Allowable Heights for Side Fix Balustrade' for other Wind Zones
 - For fixing to substrate crs.
 - Stiffener Brkts and
 - Swimming Pool fences
- 2 - Glass thickness, mm.
Glass type T= Toughened, L = Laminated, SG = SentryGlas
- 3 - All measurements mm
- 4 - Use 4x Posiglaze Clamps/m except 21.52SG @ 5 Clamps/m

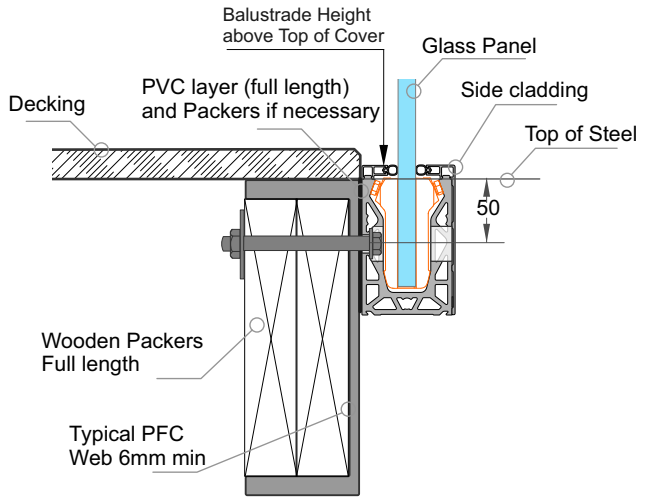

Important Installation notes:

- 1 - The Project Engineer must ensure the structure can support the appropriate loads
- 2 - Substructure shown indicatively only. Timber SG8 minimum strength
- 3 - An PVC tape layer must be placed between the Channel and Steel
- 4 - Use Threadlok on all Clamp Pressure Screws
- 5 - All fixings must be Stainless Steel

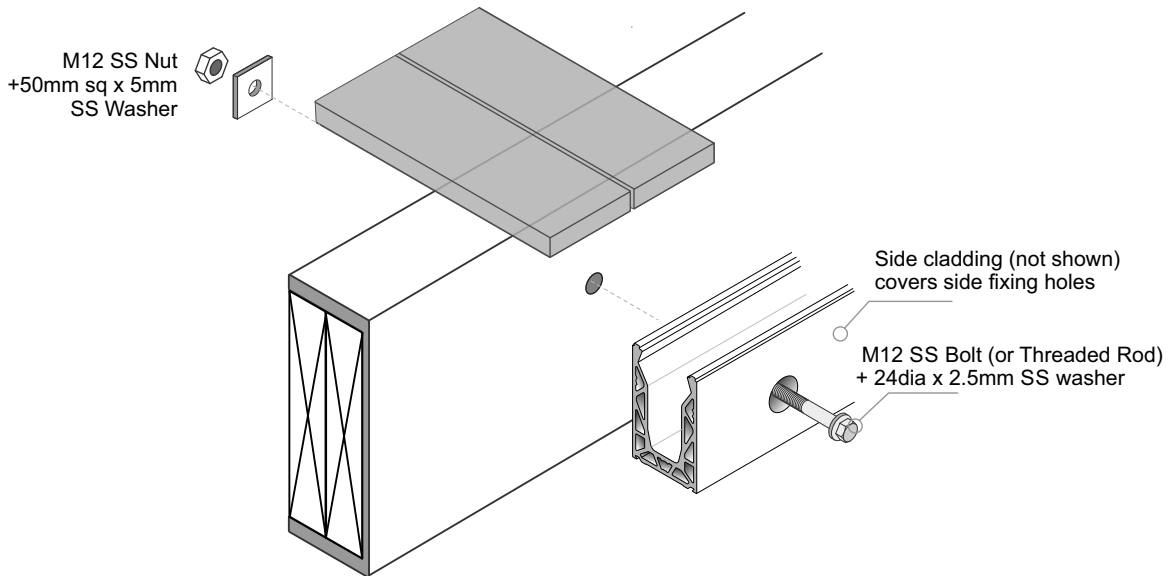

Juralco Edgetec® PosiGlaze™ Balustrade System Typical Fixing - Side Fix

Typical SIDE Fix to Concrete - M12 SS Threaded Rod Stud

**Maximum Balustrade Heights.
Up to and including Extra High Wind Zone.**

Glass Thickness/Height/Type for this mounting only

Residential Occupancy A, A Other and C3		Commercial Occupancy B, E and C3		Commercial Occupancy C1/C2 and D	
Glass Thickness, Type	Balustrade Height (max)	Glass Thickness, Type	Balustrade Height (max)	Glass Thickness, Type	Balustrade Height (max)
12 T	1050	15 T	1200	21.52SG	1100
13.52 SG	1050	17.2 L	1200		
15.2 L	1050	17.52SG	1200		
		21.52SG	1400		

Concrete Type	Uncracked	Cracked
Slab Thickness min (y)	150	210
Anchorage Depth min (x)	100	125
Hole to Concrete Edge min (z)	100	150

General Notes:

- 1 - Refer page, 'Allowable Heights for Side Fix Balustrade' for other Wind Zones
- For fixing to substrate crs.
- Stiffener Brkts and
- Swimming Pool fences
- 2 - Glass thickness, mm.
Glass type T= Toughened, L = Laminated, SG = SentryGlas
- 3 - All measurements mm
- 4 - Use 4x Posiglaze Clamps/m except 21.52SG @ 5 Clamps/m

For Uncracked Concrete



Installation details Fischer FIS V 300T

Thread diameter M12
 Drill hole diameter = 14 mm
 Drill hole depth = (x) +10mm
 Anchorage depth = (x) mm

Drilling method Hammer drilling
 Drill hole cleaning 4 times blowing,
 4 times brushing,
 4 times blowing

No borehole cleaning required in case of using a hollow drill bit, e.g. fischer FHD.

For Cracked Concrete



Installation details Hilti HIT-RE 500 V4 +M12 has A4

Thread diameter M12
 Drill hole diameter = 14 mm
 Drill hole depth = (x) +10mm
 Anchorage depth = (x) mm

Drilling method Hammer drilling
 Drill hole cleaning 4 times blowing,
 4 times brushing,
 4 times blowing

No borehole cleaning required in case of using a hollow drill bit.

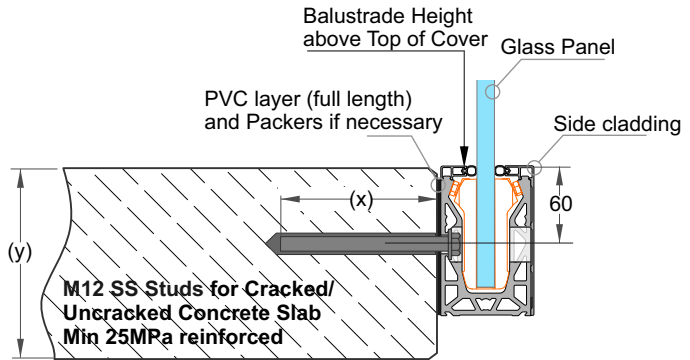

Stud projection = 18mm + any packers

Important Installation Notes:

- 1 - The Project Engineer must ensure the structure can support the appropriate loads
- 2 - Substructure shown indicatively only
- 3 - Fixings must engage into the structural slab
- 4 - A PVC Tape layer must be installed between the Channel and Concrete
- 5 - Use Threadlok on Nuts and Clamp Pressure screws
- 6 - All fixings must be Stainless Steel

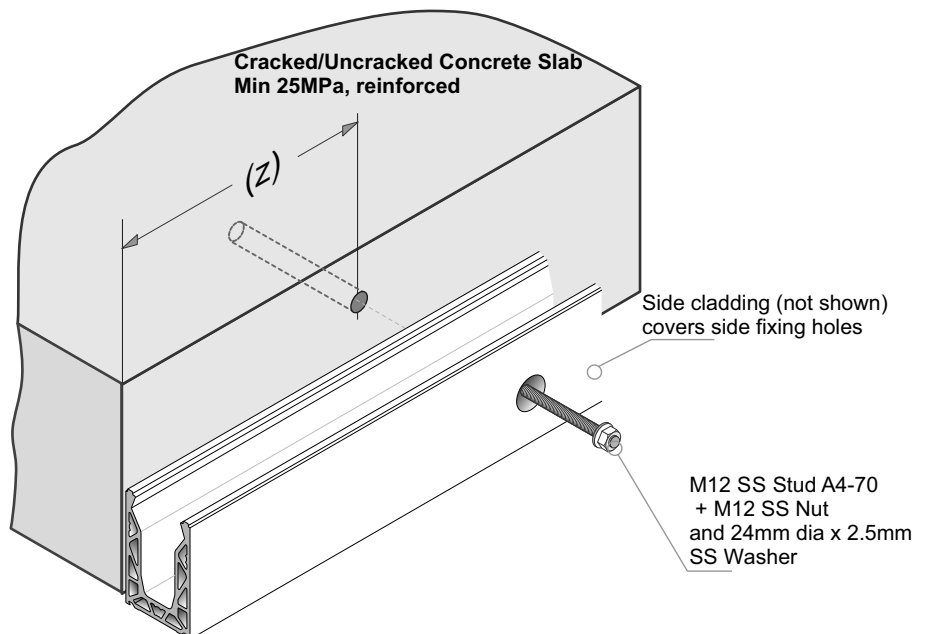

Juralco Edgetec® PosiGlaze™ Balustrade System
Options for Typical Fixing - Suspended Deck/Side Fix

Typical SIDE Fix to Concrete - M12 SS Stud or FACE FIX to Steel - M12 SS Bolt

NOTE - These are non standard fixing details and must be confirmed by the Project engineer (Site Specific PS1 is required)

**Maximum Balustrade Heights.
Up to and including Extra High Wind Zone.**

Residential Occupancy A, A Other and C3		Commercial Occupancy B, E and C3		Commercial Occupancy C1/C2 and D	
Glass Thickness, Type	Balustrade Height (max)	Glass Thickness, Type	Balustrade Height (max)	Glass Thickness, Type	Balustrade Height (max)
12 T	1050	15 T	1200	21.52SG	1100
13.52 SG	1050	17.2 L	1200		
15.2 L	1050	17.52SG	1200		
		21.52SG	1400		

Glass Thickness/Height/Type for this mounting only

General Notes:

- 1 - Refer page, 'Allowable Heights for Side Fix Balustrade' for other Wind Zones
- For fixing to substrate crs.
- Stiffener Brkts and
- Swimming Pool fences
- 2 - Glass thickness, mm.
Glass type T= Toughened, L = Laminated, SG = SentryGlas
- 3 - All measurements mm
- 4 - Use 4x Posiglaze Clamps/m except 21.52SG @ 5 Clamps/m

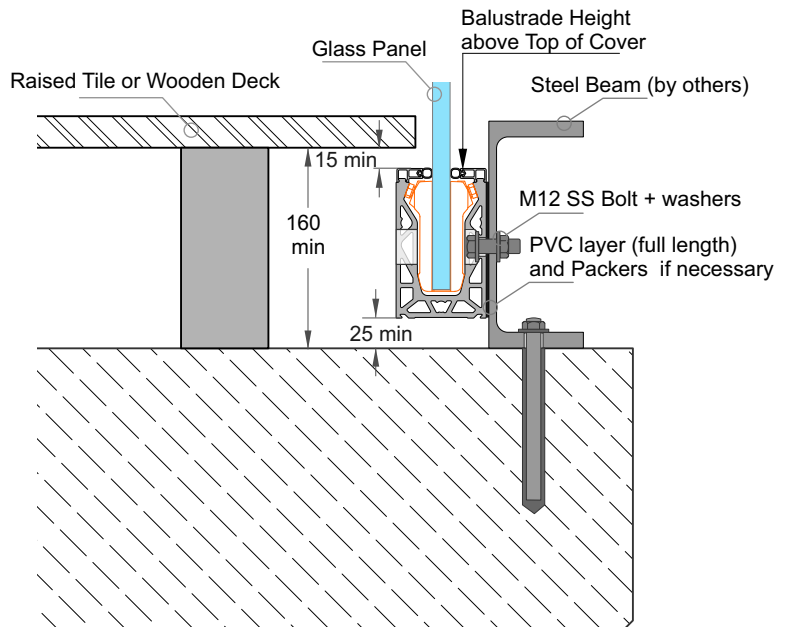
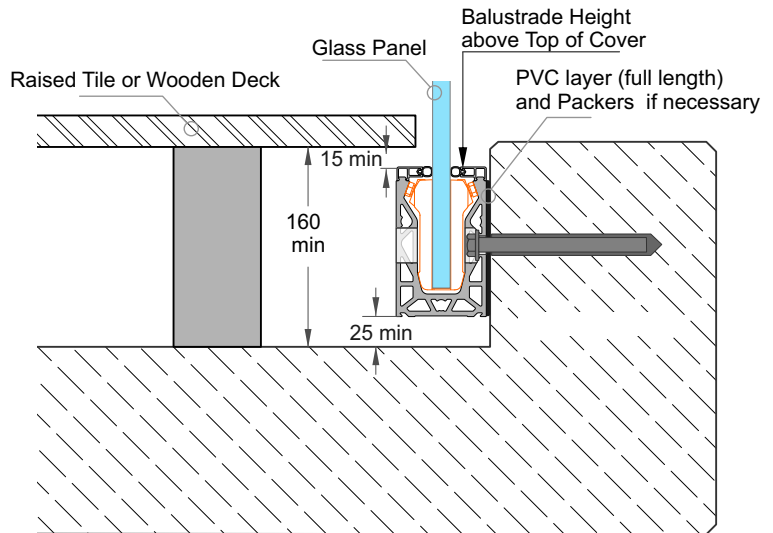

Important Installation Notes:

- 1 - The Project Engineer must ensure the structure can support the appropriate loads
- 2 - Substructure shown indicatively only
- 3 - Fixings must engage into the structural slab
- 4 - A PVC layer must be installed between the Channel and Steel/Concrete
- 5 - Use Threadlok on Nuts and Clamp Pressure screws
- 6 - All fixings must be Stainless Steel

Juralco Edgetec® PosiGlaze™ Balustrade System Typical Layouts - Base Fix

PosiGlaze Balustrade System
Base Fix + Interlinking Rail

Glass must have a minimum strength of 100Mpa. Seen edges polished

Residential Occupancy types A, A Other and C3, for
- 12mm Toughened
- 15.2mm Laminated Glass
- 13.52mm SentryGlas

Refer page, 'Allowable Heights for Base Fix Balustrade' for differing Wind Zones

See individual Mounting pages for construction options

Use 4 x Clamps per m

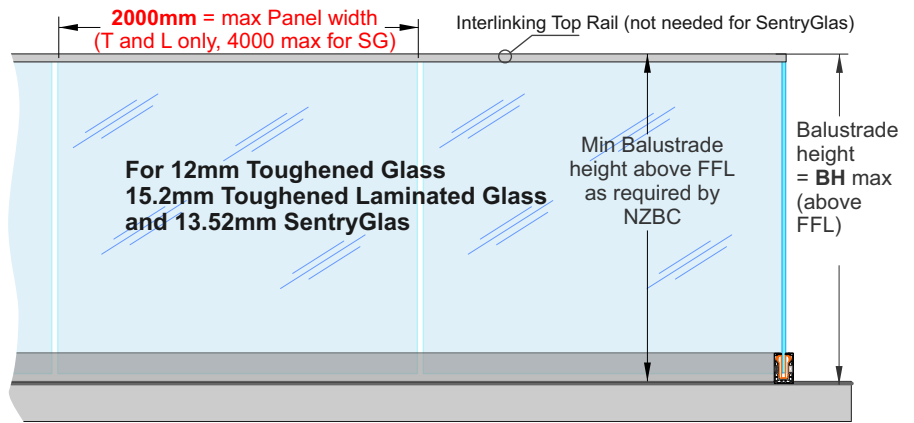

Exceeds the wind loading for all Wind Zones up to **and including Extra Wind Zone** as set out in NZS 3604:2011

Refer to the Interlinking Top Rail page for conformance to NZS 4223.3.2016.

PosiGlaze Balustrade System
Base Fix + Interlinking Rail

Glass must have a minimum strength of 100Mpa. Seen edges polished

Commercial Occupancy types B, E and C3, for
- 15mm Toughened
- 17.2mm Laminated Glass
- 17.52mm SentryGlas

Refer page, 'Allowable Heights for Base Fix Balustrade' for differing Wind Zones

See individual Mounting pages for construction options

Use 4 x Clamps per m

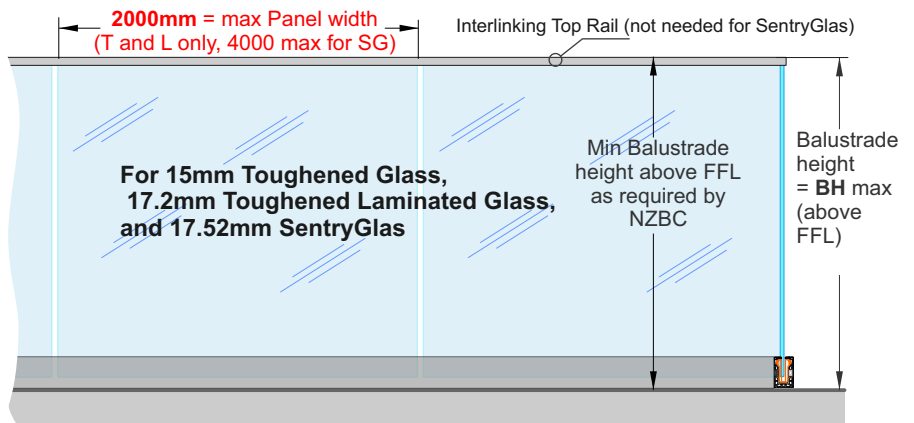

Exceeds the wind loading for all Wind Zones up to **and including Extra High Wind Zone** as set out in NZS 3604:2011

Refer to the Interlinking Top Rail page for conformance to NZS 4223.3.2016.

PosiGlaze Balustrade System
Base Fix

POOL FENCING only

Glass must have a minimum strength of 100Mpa. Seen edges polished

Applies to Swimming Pools as of Jan 2017, complies with the Building Code clause F9 and section 162C of the Building Act.

Applies to Pool Fences not protecting a fall of 1.0m or more

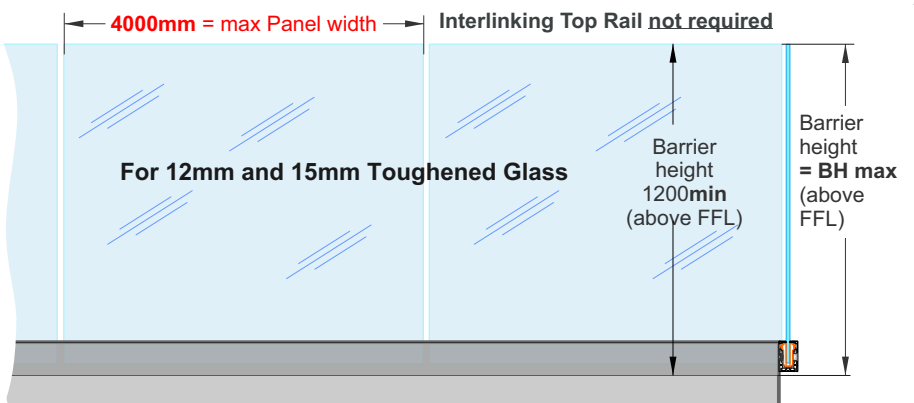

12mm Toughened - Up to and including **Very High Wind Zone.**

15mm Toughened - Up to and including **Extra High Wind Zone**

Juralco Edgetec® PosiGlaze™ Balustrade System Typical Layouts - Base Fix

PosiGlaze Balustrade System Base Fix + Stiffener Brackets

Glass must have a minimum strength of 100Mpa. Seen edges polished

Residential Occupancy types A, A Other and C3, for
- 15.2mm Laminated Glass
- 13.52mm SentryGlas

Refer page, 'Allowable Heights for Base Fix Balustrade' for differing Wind Zones

See individual Mounting pages for construction options

Use 4 x Clamps per m

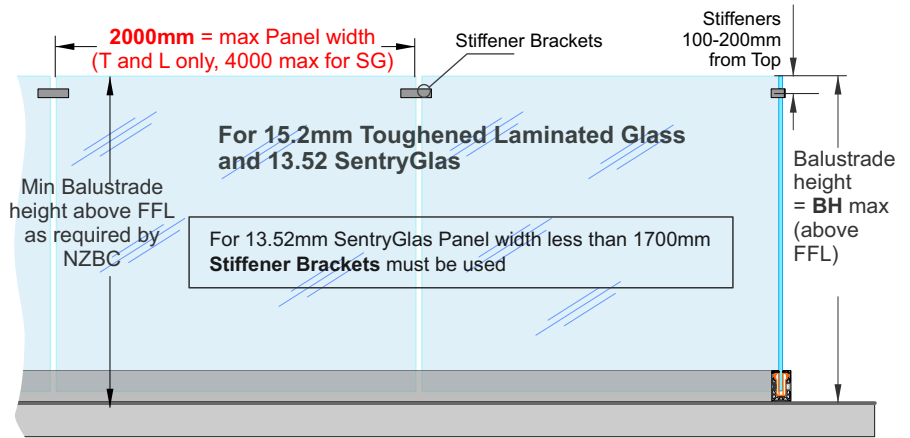

Exceeds the wind load **Extra Wind Zone** as set out in NZS 3604:2011

Refer to the Stiffener Bracket pages for conformance to NZS 4223.3.2016.

PosiGlaze Balustrade System Base Fix + Stiffener Brackets

Glass must have a minimum strength of 100Mpa. Seen edges polished

Commercial Occupancy types B, E and C3, for
- 17.2mm Laminated Glass
- 17.52mm SentryGlas

Refer page, 'Allowable Heights for Base Fix Balustrade' for differing Wind Zones

See individual Mounting pages for construction options

Use 4 x Clamps per m

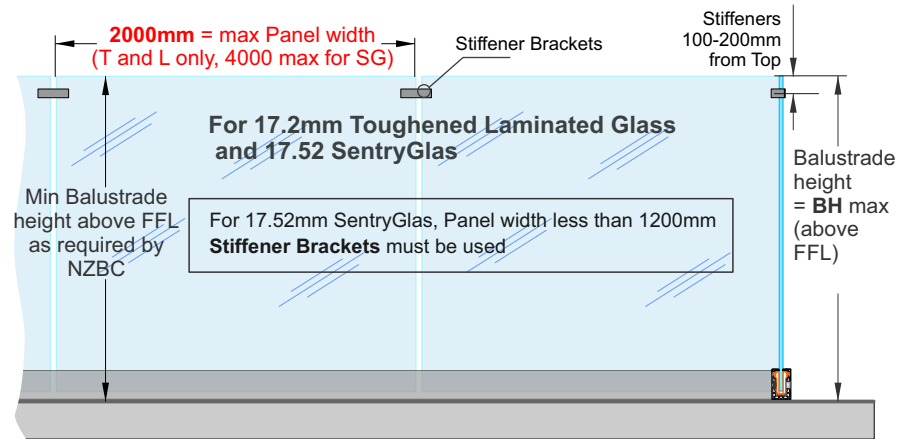

Exceeds the wind loading for all Wind Zones up to **and including Extra High Wind Zone** as set out in NZS 3604:2011

Refer to the Stiffener Bracket pages for conformance to NZS 4223.3.2016.

PosiGlaze Balustrade System Base Fix + Stiffener Brackets

Glass must have a minimum strength of 100Mpa. Seen edges polished

Commercial Occupancy types B, E and C3, for
- 21.52mm SentryGlas

Commercial Occupancy types C1/C2 and D, for
- 21.52mm SentryGlas

Refer page, 'Allowable Heights for Base Fix Balustrade' for differing Wind Zones

See individual Mounting pages for construction options

Must use 5 x Clamps per m

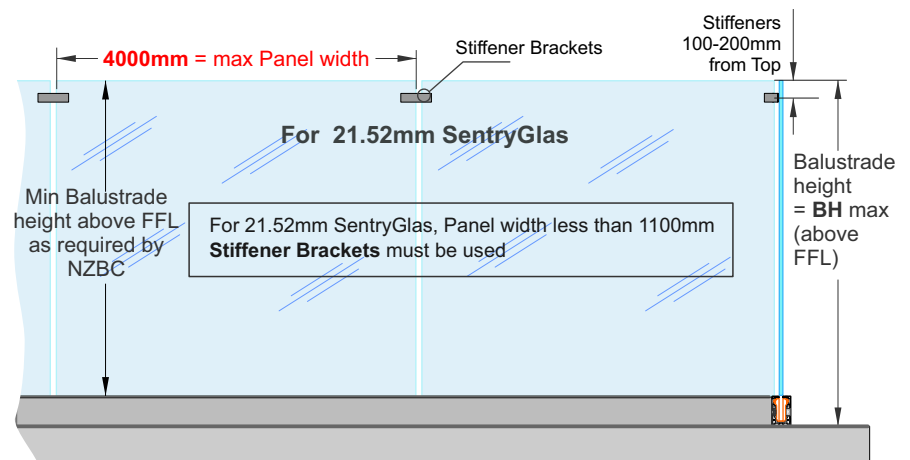

Applies to 21.52mm SentryGlas mounted to Steel or Concrete. Not to Timber.

Exceeds the wind loading for all Wind Zones up to **and including Extra High Wind Zone** as set out in NZS 3604:2011

Refer to the Stiffener Bracket pages for conformance to NZS 4223.3.2016.

**Juralco Edgetec® PosiGlaze™ Balustrade System
Typical Layouts - Pool Stairs/Steps - Base Fix**

Base Fix PosiGlaze
Pool Access **Stairs**

Important Note:
 - Up to and including Medium Wind Zone
 - Applies to Base Fix Posiglaze
 - Final Panel below Stairs must finish at BH 1200mm

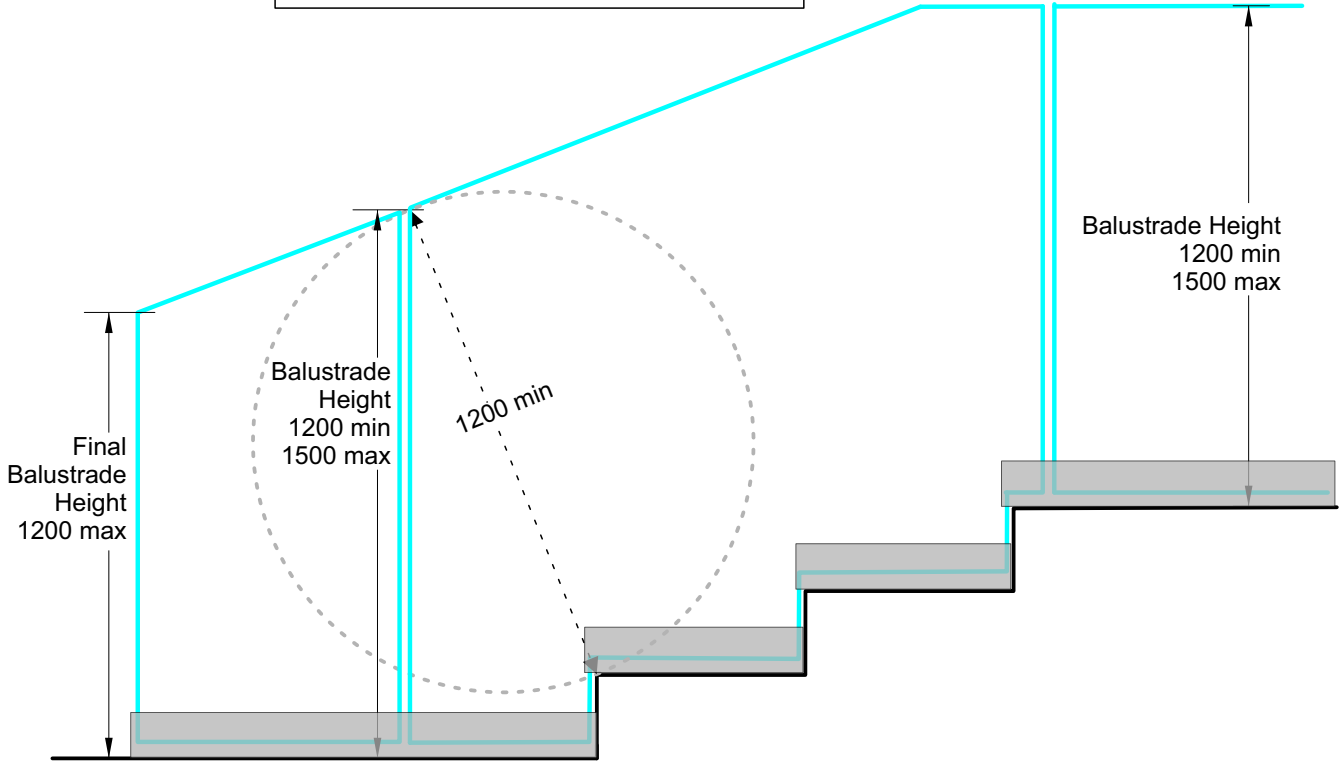

Base Fix PosiGlaze
Pool Access **Steps**

Important Note:
 - Up to and including Medium Wind Zone
 - Applies to Base Fix Posiglaze
 - Final Panel below Step must finish at BH 1200mm

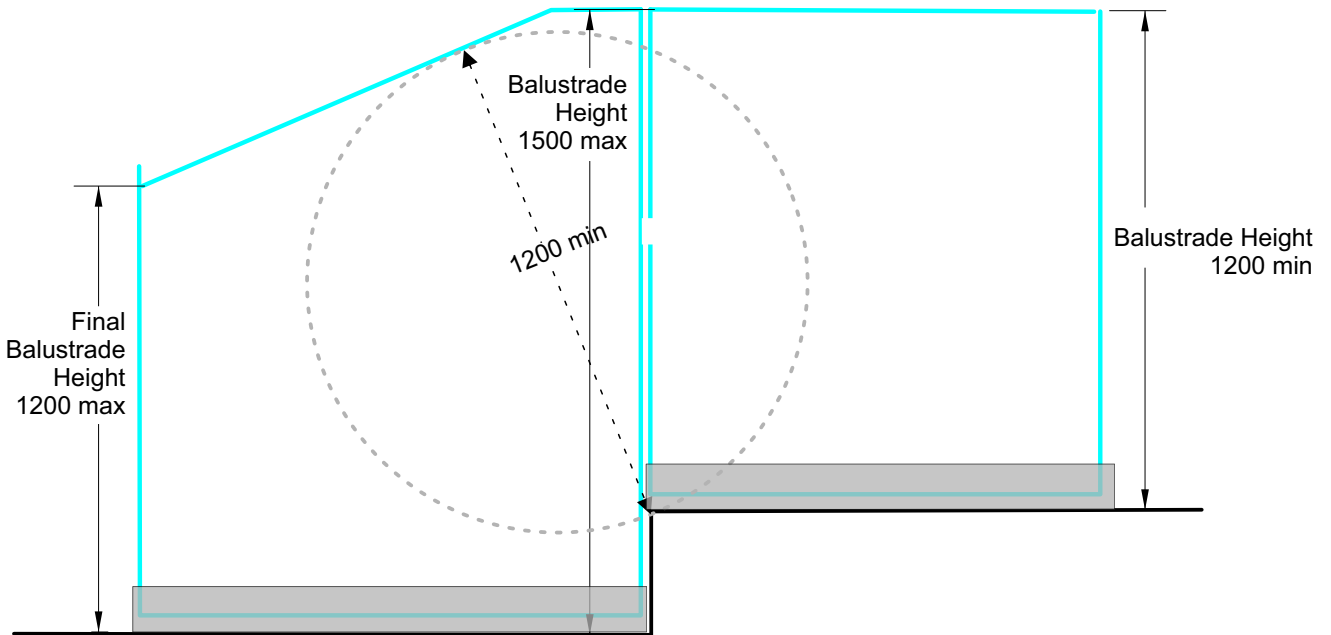

Juralco Edgetec® PosiGlaze™ Balustrade System Base Fix General

Juralco PosiGlaze
Glass Balustrade
Base Fix
(15mm Glass Shown)

Orange outline. Glass Panel Clamps
at Specified intervals.
Clamping/aligning bolt heads accessible
before Gasket Holders clip in place

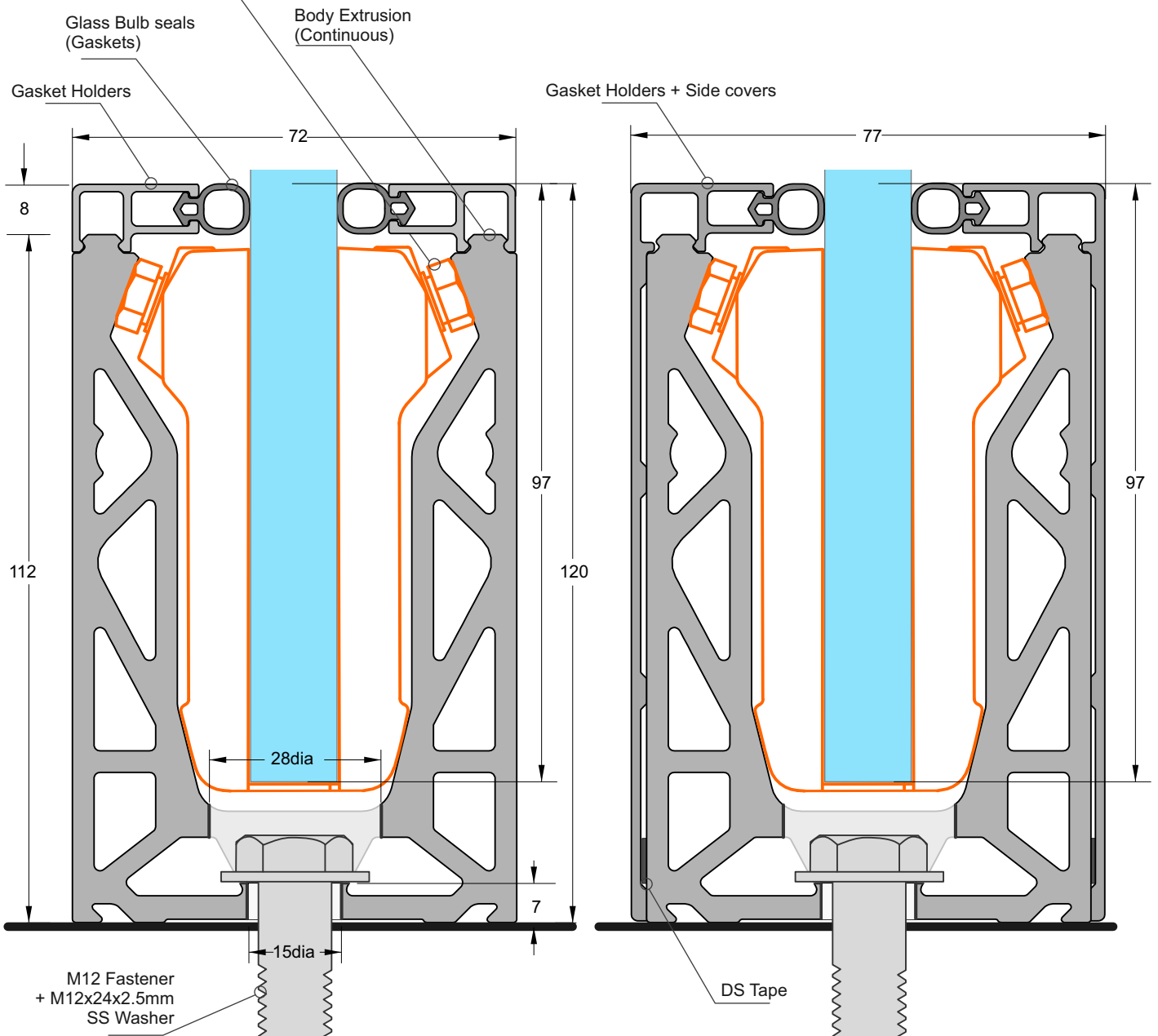

Allowable Heights for Base Fix Balustrade

Glass Thickness, Type	Wind Zone	Barrier Height, mm (max above Clamp)	Fix attach centres, mm
Residential Occupancy A, A Other and C3 only			
12mm Toughened @4xPosiglaze Clamps/m	High	1350	200
	Very High	1200	200
	Extra High	1075	200
13.52mm SentryGlas @4xPosiglaze Clamps/m	High	1350 ^{NOTE 3}	200
	Very High	1200 ^{NOTE 3}	200
	Extra High	1075	200
15.2mm Laminated @4xPosiglaze Clamps/m	High	1350	200
	Very High	1200	200
	Extra High	1075	200
Commercial Occupancy B, E and C3 only			
15mm Toughened @4xPosiglaze Clamps/m	High	1600	200
	Very High	1400	200
	Extra High	1300	200
17.2mm Laminated @4xPosiglaze Clamps/m	High	1600	200
	Very High	1400	200
	Extra High	1300	200
17.52mm SentryGlas @4xPosiglaze Clamps/m	High	1600 ^{NOTE 3}	200
	Very High	1400 ^{NOTE 3}	200
	Extra High	1300 ^{NOTE 3}	200
21.52mm SentryGlas (Mounting to Steel or Concrete only, not Timber) @5xPosiglaze Clamps/m	High	1850	200
	Very High	1650	200
	Extra High	1450	200
Commercial Occupancy C1/C2, D only			
Glass Thickness, Type	Wind Zone	Barrier Height, mm (max above Clamp)	Fix attach centres, mm
21.52mm SentryGlas (Mounting to Steel or Concrete only, not Timber) @5xPosiglaze Clamps/m	Extra High	1200	200

Layered Glasses, Construction

Laminated Glass Layers and Thickness Orientation			
Glass Thickness (mm)	Inner Layer of Glass thickness (mm) Deckside	Interlayer thickness (mm) and Type	Outer Layer Glass thickness (mm)
15.2	6	1.2 EVA	8
17.2	8	1.2 EVA	8
SentryGlas® Glass Layers and Thickness Orientation			
Glass Thickness (mm)	Inner Layer of Glass thickness (mm) Deckside	Interlayer thickness (mm) and Type	Outer Layer Glass thickness (mm)
13.52	6	1.52 SG	6
17.52	8	1.5 SG	8
21.52	10	1.52 SG	10

Notes.

Note 1: For Toughened Glass Interlinking Rails or Handrails MUST be used. Not for use with Stiffener Brackets

Note 2: Laminated Glass Interlinking Rails, Handrails or Stiffener Brackets may be used.

Note 3: SentryGlas Interlinking Rails, Handrails or Stiffener Brackets may be used, but see table below.

For SentryGlas, Stiffener Brackets MUST be used above these Heights or below these Widths

Glass Thickness, Type	Barrier Height, mm (max above FFL)	Panel Width, mm (minimum)
13.52mm SentryGlas	1050	1700mm
17.52mm SentryGlas	1150	1200mm
21.52mm SentryGlas	1150	1100mm

For Pool Fencing only - Base Fix only

Applies to Pool Fences not protecting a fall of 1.0m or more

Wind Zone up to and Including	Heights for, Glass 12mm Toughened	Heights for, Glass 15mm Toughened	Fix attach crs, mm
Medium	1500mm	1700mm	200mm
High	1350mm	1550mm	200mm
Very High	1250mm	1350mm	200mm
Extra High	NA	1250mm	200mm

**Juralco Edgetec® PosiGlaze™ Balustrade System
Design Loads**

Max Design Loads - all for Base Fix only

For use by Project Engineers to develop Site Specific designs

PosiGlaze Base Fix only				Max Design loads to substructure (per fixing point)		Wind Pressures (ULS to SLS Factor 0.75)		
Glass Type & Thickness (mm)	Occupancy	Max Height (mm)	Fixing Centres (mm)	T* (kN)	V*(kN)	Wind Zones	ULS	SLS
12T, 13.52SG, 15.2L	Residential Occupancy A, A Other and C3	1350	200	15	0.57	High	1.69	1.27
		1200	200	15	0.65	Very High	2.2	1.65
		1075	200	13.61	0.7	Extra High	2.69	2.02
15T, 17.52SG, 17.2L	Commercial Occupancy B, E and C3	1600	200	16	0.68	High	1.66	1.25
		1400	200	16	0.76	Very High	2.17	1.63
		1300	200	16	0.86	Extra High	2.64	1.98
21.52SG	Commercial Occupancy B, E and C3	1850	200	20.94	0.79	High	1.74	1.31
		1650	200	21.53	0.91	Very High	2.27	1.7
		1450	200	20.11	0.96	Extra High	2.78	2.09
	Commercial C1/C2	1200	200	19	0.79	Extra High	2.82	2.12
12T, 15T	Pool Fencing Only	1250	200	14.25	0.78	Extra High	2.82	2.12

**Notes : 1 - Refer previous page for additional information
2 - Glass type T= Toughened, L = Laminated, SG = SentryGlas**

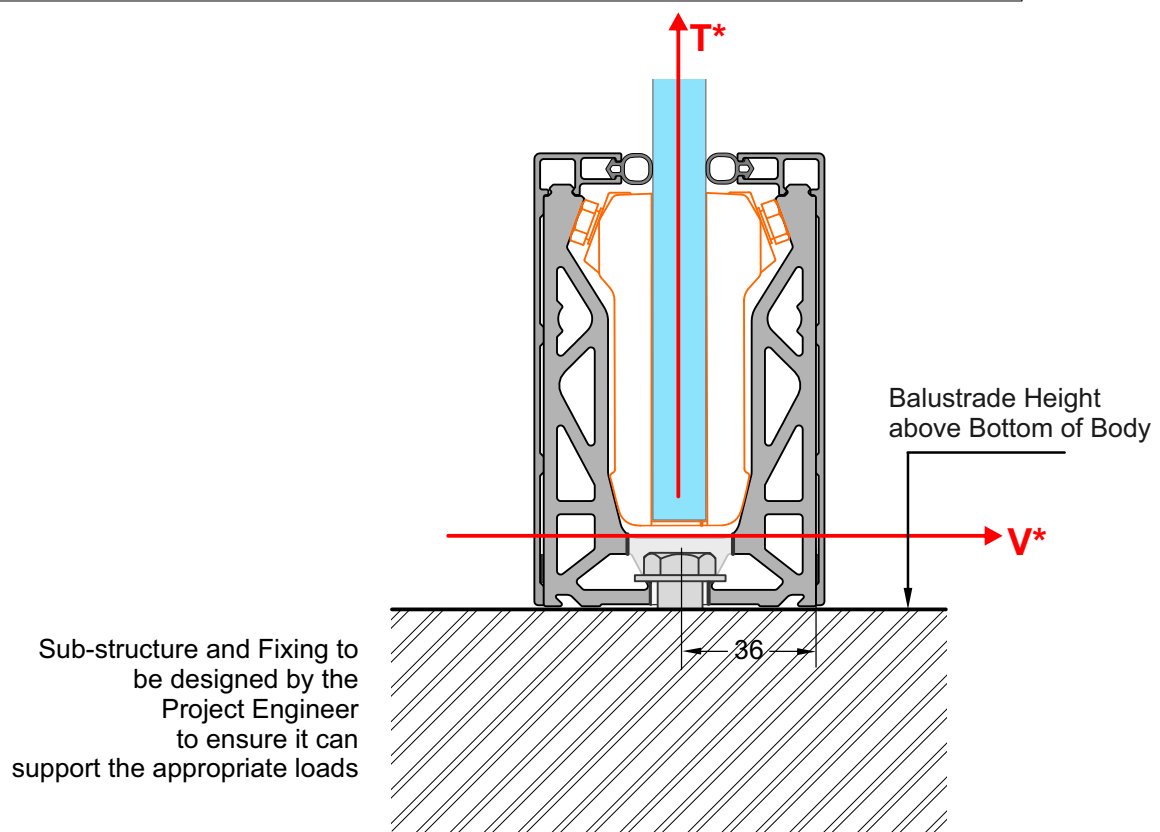

Juralco Edgetec® PosiGlaze™ Balustrade System Typical Fixing - Base Fix

Typical BASE Fix to Timber, Single Joist - M12 SS Coachscrew

Complies with NZS3604:2011 - Single Boundary Joist

**Maximum Balustrade Heights.
Up to and including
Extra High Wind Zone.**

Residential Occupancy A, A Other and C3		Commercial Occupancy B, E and C3	
Glass Thickness, Type	Balustrade Height (max)	Glass Thickness, Type	Balustrade Height (max)
12 T	1075	15 T	1300
13.52 SG	1075	17.2 L	1300
15.2 L	1075	17.52SG	1300

Glass Thickness/Height/Type for this mounting type only

General Notes:

- 1 - Refer page, 'Allowable Heights for Base Fix Balustrade' for other Wind Zones
 - For fixing to substrate crs.
 - Stiffener Brkts and
 - Swimming Pool fences
- 2 - Glass thickness, mm.
Glass type T= Toughened, L = Laminated, SG = SentryGlas
- 3 - All measurements mm
- 4 - Use 4x Posiglaze Clamps/m

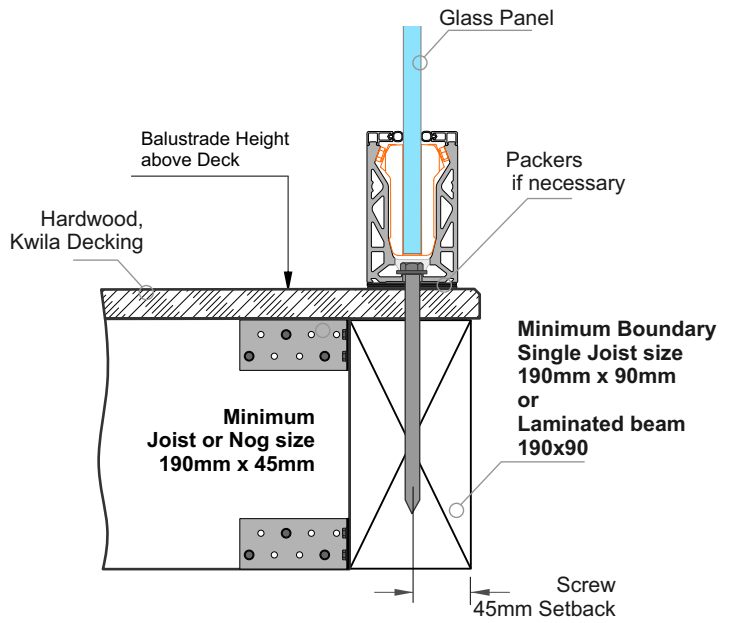

Important Installation notes:

- 1 - The Project Engineer must ensure the structure can support the appropriate loads
- 2 - Substructure shown indicatively only. Timber SG8 minimum strength
- 3 - Coachscrews 150mm min engagement into joists, predrill 6mm holes.
- 4 - Bond all coachscrews with SIKA Supergrip30 to full depth
- 5 - Use Threadlok on all Clamp Pressure Screws
- 6 - All Fixings must be Stainless steel

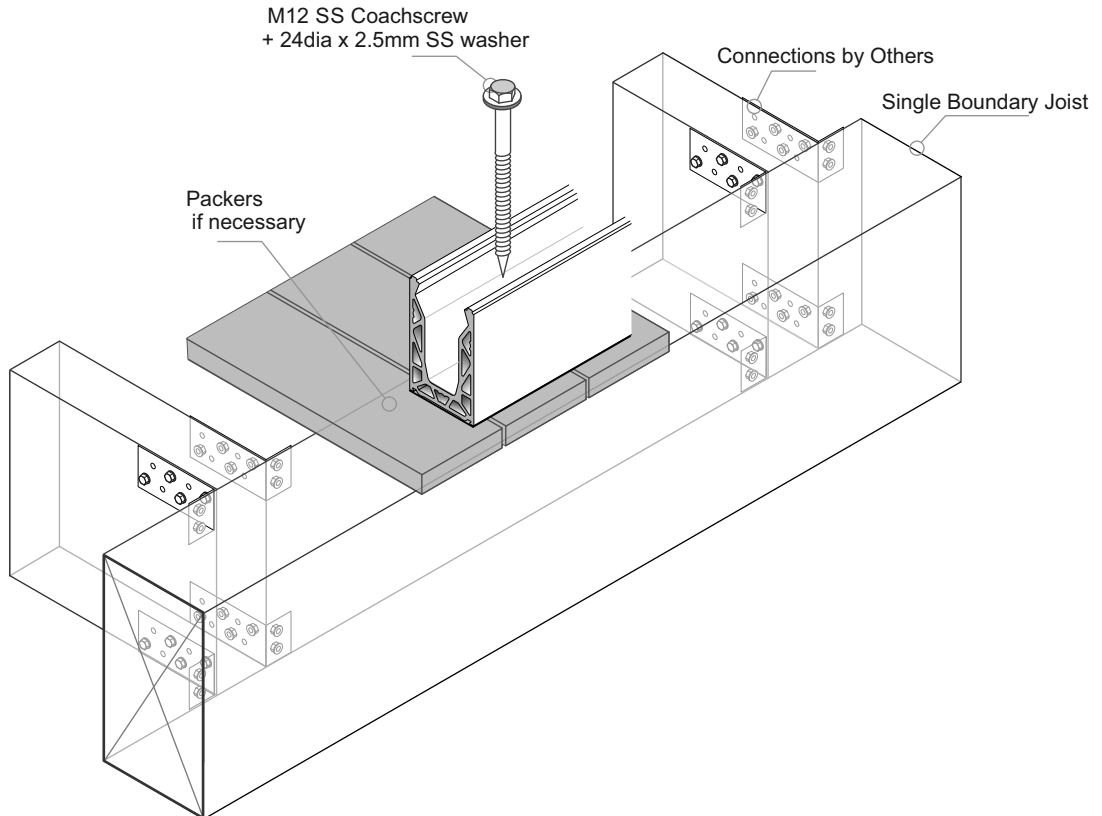

Juralco Edgetec® PosiGlaze™ Balustrade System Typical Fixing - Base Fix

Typical BASE Fix to Timber, Triple Joist - M12 SS Coachscrew

**Maximum Balustrade Heights.
Up to and including
Extra High Wind Zone.**

Residential Occupancy A, A Other and C3		Commercial Occupancy B, E and C3	
Glass Thickness, Type	Balustrade Height (max)	Glass Thickness, Type	Balustrade Height (max)
12 T	1075	15 T	1300
13.52 SG	1075	17.2 L	1300
15.2 L	1075	17.52SG	1300

Glass Thickness/Height/Type for this mounting type only

General Notes:

- 1 - Refer page, 'Allowable Heights for Base Fix Balustrade' for other Wind Zones
- For fixing to substrate crs.
- Stiffener Brkts and
- Swimming Pool fences
- 2 - Glass thickness, mm.
Glass type T= Toughened, L = Laminated, SG = SentryGlas
- 3 - All measurements mm
- 4 - Use 4x Posiglaze Clamps/m

Complies with NZS3604:2011 - Triple Boundary Joist

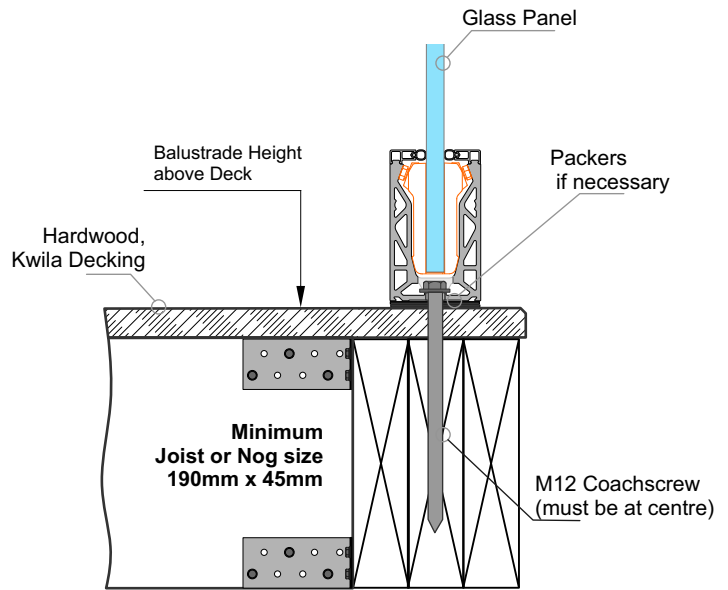

Important Installation notes:

- 1 - The Project Engineer must ensure the structure can support the appropriate loads
- 2 - Substructure shown indicatively only. Timber SG8 minimum strength
- 3 - Coachscrews 150mm min engagement into joists, predrill 6mm holes.
- 4 - Bond all coachscrews with SIKa Supergrip30 to full depth
- 5 - Use Threadlok on all Clamp Pressure Screws
- 6 - All Fixings must be Stainless steel

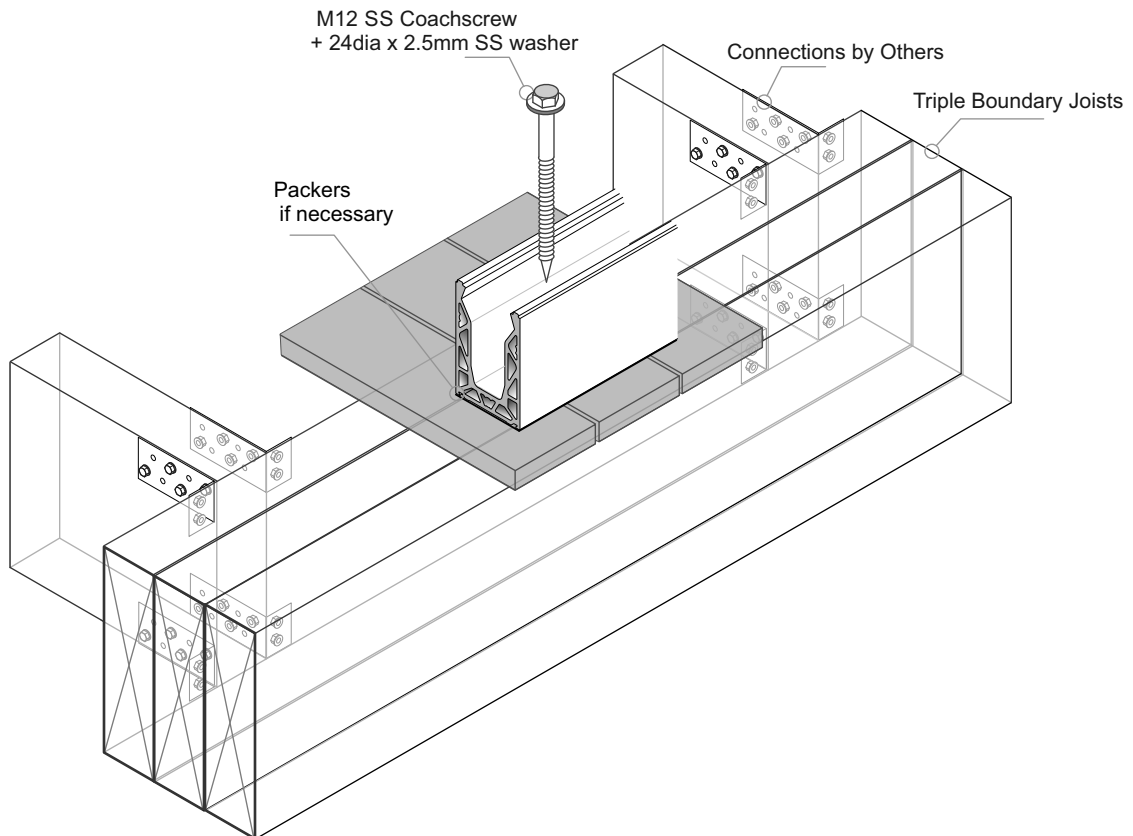

Juralco Edgetec® PosiGlaze™ Balustrade System Typical Fixing - Base Fix

Typical BASE Fix to Steel + Timber Deck - M12 SS, Bolt or Threaded Rod

Maximum Balustrade Heights. Up to and including Extra High Wind Zone.

Residential Occupancy A, A Other and C3		Commercial Occupancy B, E and C3		Commercial Occupancy C1/C2 and D	
Glass Thickness, Type	Balustrade Height (max)	Glass Thickness, Type	Balustrade Height (max)	Glass Thickness, Type	Balustrade Height (max)
12 T	1075	15 T	1300	21.52SG	1200
13.52 SG	1075	17.2 L	1300		
15.2 L	1075	17.52SG	1300		
		21.52SG	1450		

Glass Thickness/Height/Type for this mounting only

General Notes:

- 1 - Refer page, 'Allowable Heights for Base Fix Balustrade' for other Wind Zones
 - For fixing to substrate crs.
 - Stiffener Brkts and
 - Swimming Pool fences
- 2 - Glass thickness, mm.
Glass type T= Toughened, L = Laminated, SG = SentryGlas
- 3 - All measurements mm
- 4 - Use 4x Posiglaze Clamps/m
except 21.52SG @ 5 Clamps/m

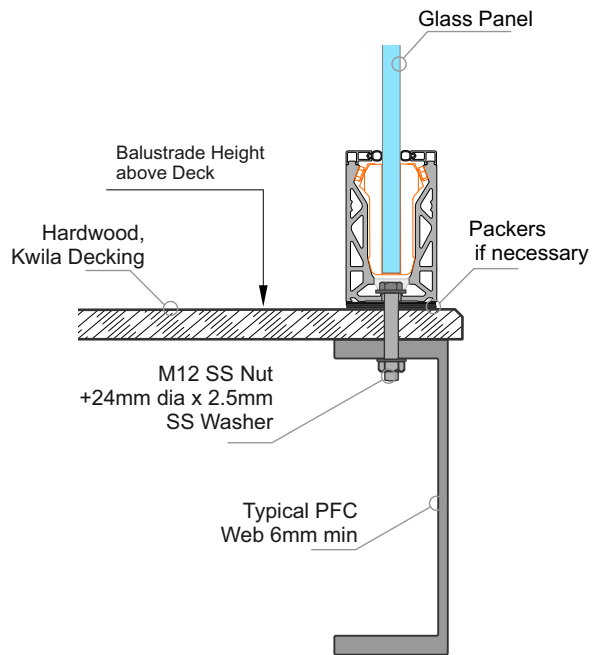

Important Installation notes:

- 1 - The Project Engineer must ensure the structure can support the appropriate loads
- 2 - Substructure shown indicatively only
- 3 - Use Threadlok on all Clamp Pressure Screws
- 4 - All fixings must be Stainless Steel

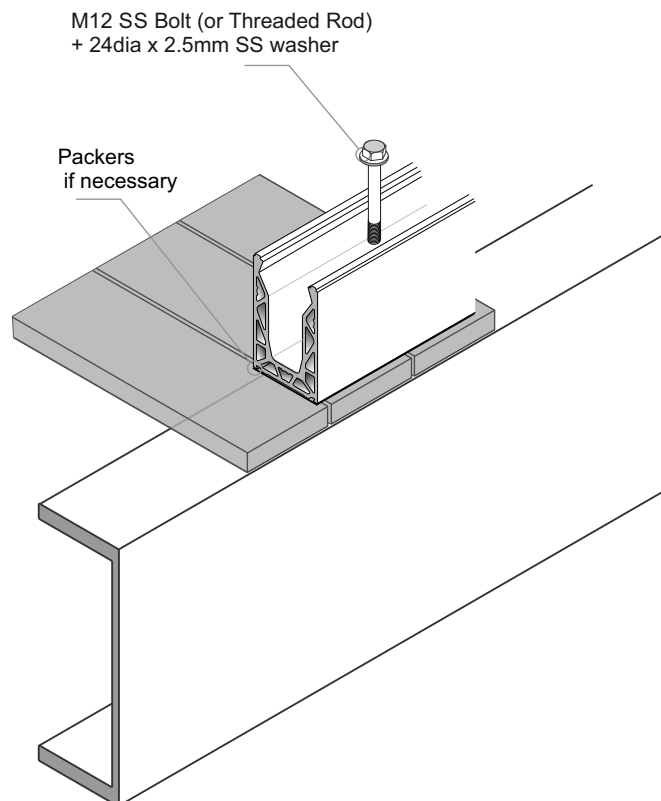

Juralco Edgetec® PosiGlaze™ Balustrade System Typical Fixing - Base Fix

Typical BASE Fix directly to Steel - M12 SS, Bolt or Threaded Rod

Maximum Balustrade Heights. Up to and including Extra High Wind Zone.

Residential Occupancy A, A Other and C3		Commercial Occupancy B, E and C3		Commercial Occupancy C1/C2 and D	
Glass Thickness, Type	Balustrade Height (max)	Glass Thickness, Type	Balustrade Height (max)	Glass Thickness, Type	Balustrade Height (max)
12 T	1075	15 T	1300	21.52SG	1200
13.52 SG	1075	17.2 L	1300		
15.2 L	1075	17.52SG	1300		
		21.52SG	1450		

Glass Thickness/Height/Type for this mounting only

General Notes:

- 1 - Refer page, 'Allowable Heights for Base Fix Balustrade' for other Wind Zones
- For fixing to substrate crs.
- Stiffener Brkts and
- Swimming Pool fences
- 2 - Glass thickness, mm.
Glass type T= Toughened, L = Laminated, SG = SentryGlas
- 3 - All measurements mm
- 4 - Use 4x Posiglaze Clamps/m except 21.52SG @ 5 Clamps/m

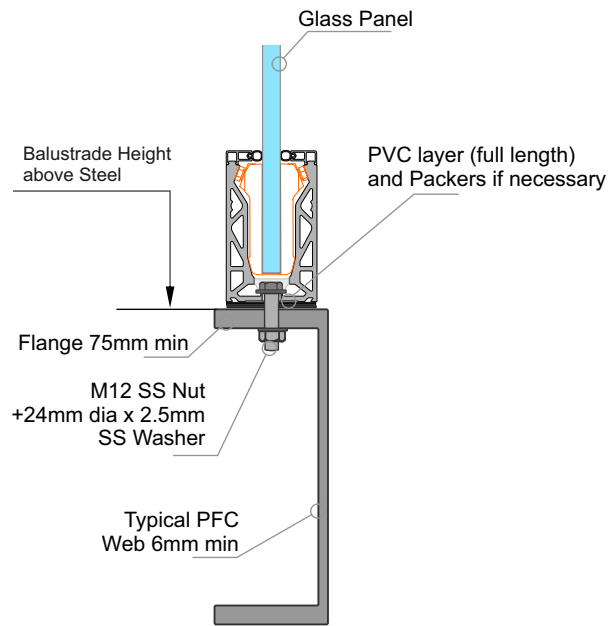

Important Installation notes:

- 1 - The Project Engineer must ensure the structure can support the appropriate loads
- 2 - An PVC Tape layer must be installed between the Channel and Steel
- 3 - Use Threadlok on all Clamp Pressure Screws
- 4 - All fixings must be Stainless Steel

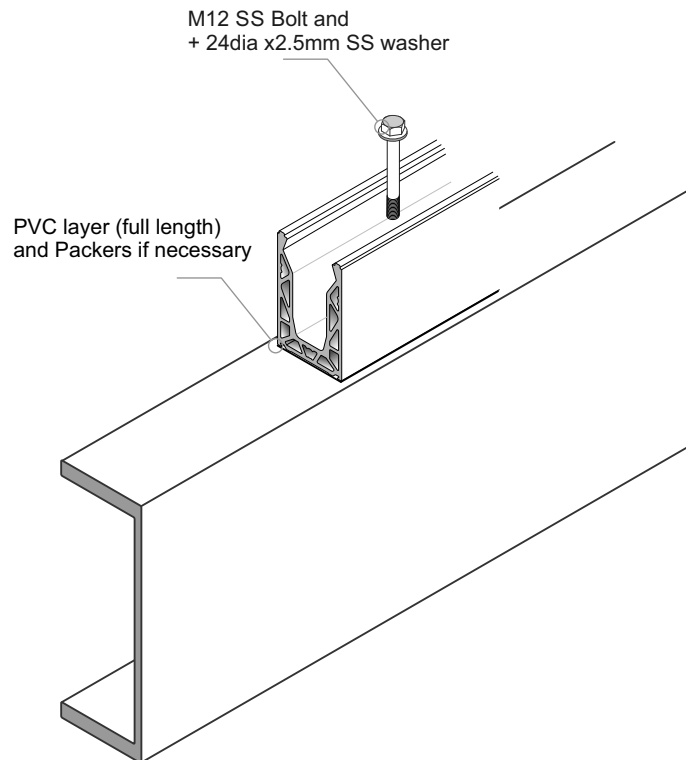

Juralco Edgetec® PosiGlaze™ Balustrade System Options for Typical Fixing - Suspended Deck/Base Fix

Typical BASE Fix to Concrete - M12 SS Threaded Rod Stud

Maximum Balustrade Heights. Up to and including Extra High Wind Zone.

Residential Occupancy A, A Other and C3	Commercial Occupancy B, E and C3	Commercial Occupancy C1/C2 and D
--	-------------------------------------	-------------------------------------

Glass Thickness, Type	Balustrade Height (max)	Glass Thickness, Type	Balustrade Height (max)	Glass Thickness, Type	Balustrade Height (max)
12 T	1075	15 T	1300	21.52SG	1200
13.52 SG	1075	17.2 L	1300		
15.2 L	1075	17.52SG	1300		
		21.52SG	1450		

Concrete Type	Uncracked	Cracked
Slab Thickness min (y)	130	210
Anchorage Depth min (x)	80	150
Hole to Concrete Edge min	100	150

General Notes:

- Refer page 'Allowable Heights for Base Fix Balustrade' for other Wind Zones
 - For fixing to substrate crs.
 - Stiffener Brkts and
 - Swimming Pool fences
- Glass thickness, mm.
 - Glass type T = Toughened, L = Laminated, SG = SentryGlas
- All measurements mm
- Use 4x Posiglaze Clamps/m

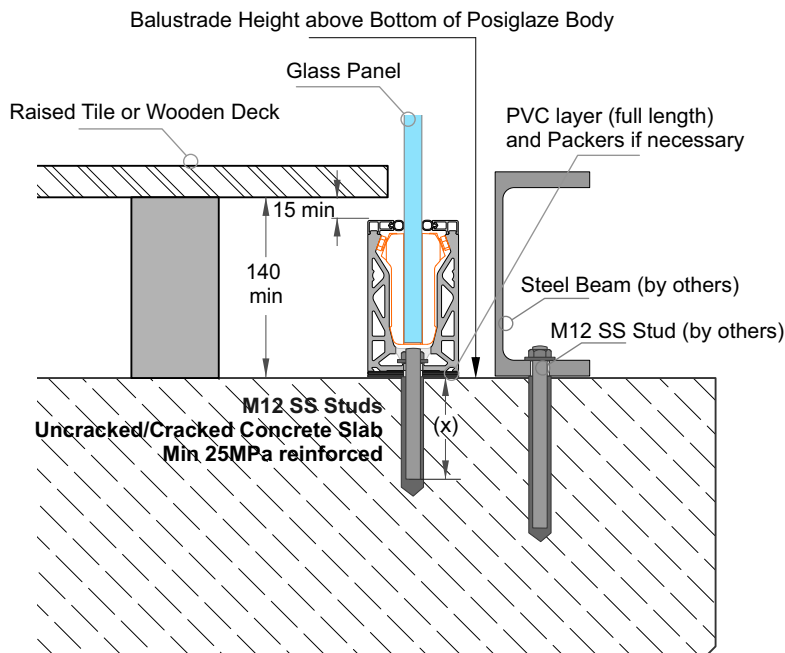
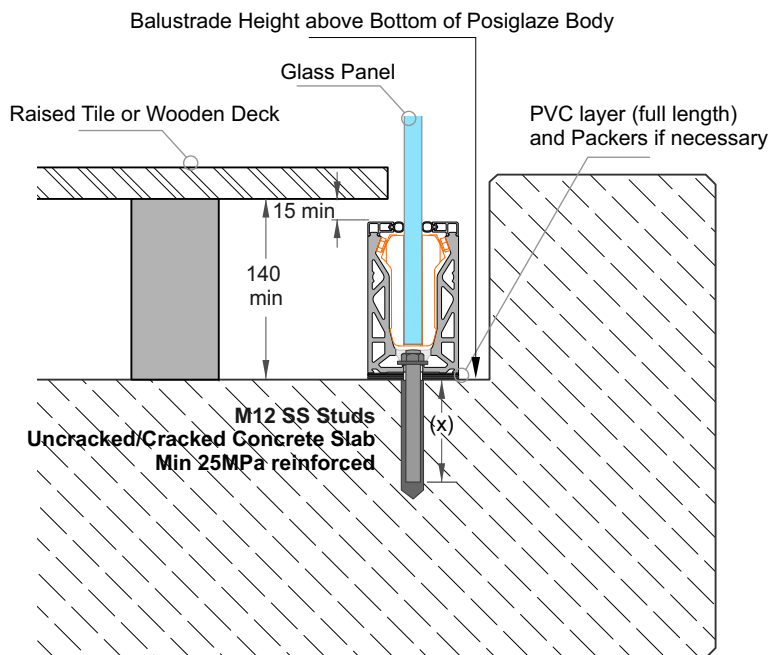

For Uncracked Concrete



Installation details Fischer FIS V 300T

Thread diameter M12
 Drill hole diameter = 14 mm
 Drill hole depth = 90 mm
 Anchorage depth = 80 mm

Drilling method Hammer drilling
 Drill hole cleaning 4 times blowing,
 4 times brushing,
 4 times blowing

No borehole cleaning required in case of using a hollow drill bit.

For Cracked Concrete



Installation details Hilti HIT-RE 500 V4 +M12 has A4

Thread diameter M12
 Drill hole diameter = 14 mm
 Drill hole depth = (x) +10mm
 Anchorage depth = (x) mm

Drilling method Hammer drilling
 Drill hole cleaning 4 times blowing,
 4 times brushing,
 4 times blowing

No borehole cleaning required in case of using a hollow drill bit.

Important Installation Notes:

- The Project Engineer must ensure the structure can support the appropriate loads
- Substructure shown indicatively only
- Fixings must engage into the structural slab
- A suitable Packer + PVC Tape layer must be installed between the Channel and Concrete
- Use Threadlok on Nuts and Clamp Pressure screws
- All fixings must be Stainless Steel

Juralco Edgetec® PosiGlaze™ Balustrade System Installation and Fitting Instructions

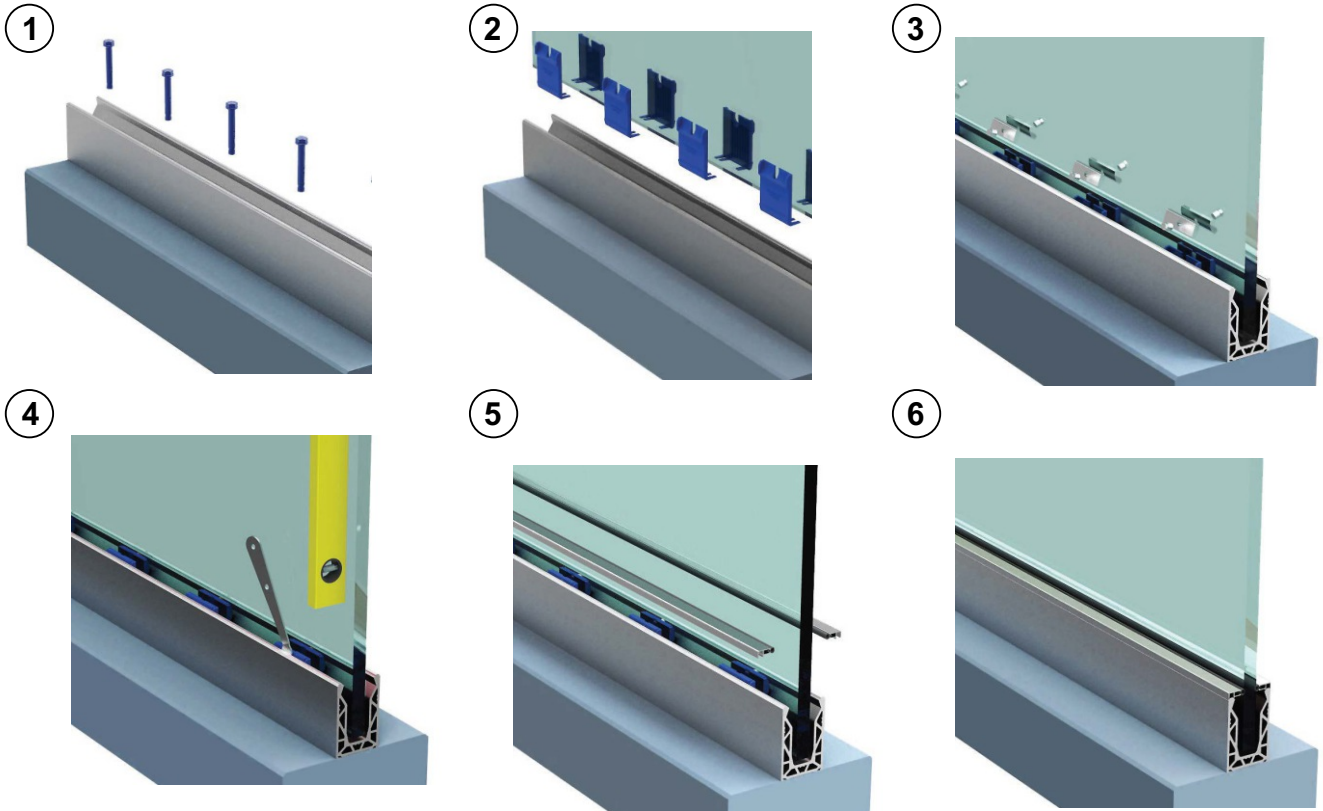

These instructions apply to both SIDE and BASE Fix PosiGlaze installations.

1. For both SIDE Fix and BASE Fix systems place the channel in position and mark the substrate surface for predrilling of holes. Start at 100mm typical or 150mm for cracked concrete from the first edge and then every 200mm or 400mm depending on specifications. Once the channel is aligned and level fastenings should be tightened to secure the channel.
2. Prepare the glass clamps and slot them onto your glass panels starting at 100mm from the first edge and then evenly for 4 or 5 clamps per m, depending on Glass type. Ensure the clamps are tight around the glass panel, then slot into the PosiGlaze channel.
3. Slide in the aluminium glass clamp bars with the curved side against the plastic glass clamp. Loosely screw the bolts into the flat side of the clamp bar to ensure no interference when inserting.
4. At this point, the glass panel should be able to move slightly in either direction. Align the panel vertically using a level and begin tightening the clamp bar bolts outward against the PosiGlaze channel. Tighten both sides as evenly as possible until the glass panel is secure and vertical. You must use a threadlocker for added security (eg: Loctite).
5. Install the top seal strips by pressing firmly or sliding on the PosiGlaze channel. Do not stretch the rubber gasket. Your top seal strips will differ between SIDE Fix and BASE Fix solutions. A rubber mallet may be required if pressing the top seal strips into place.
6. Installation is complete. Please follow our cleaning instructions in this fabrication manual for care and maintenance.

Juralco 38mm Rectangular Interlinking Top Rail

This page applies to 12mm and 15mm Toughened Glass only

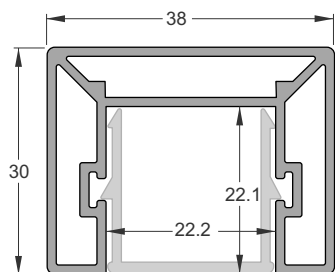

Rectangular Interlinking Top Rail
JET/220/5.8
Also showing Infill Clip, for use in between Glass Panels

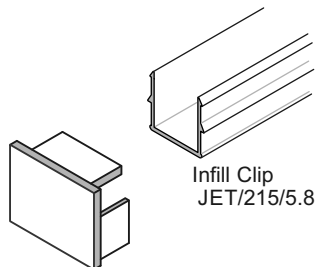

Infill Clip
Rail End Cap
JET 37

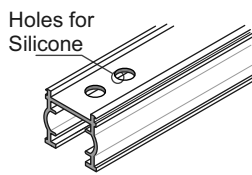

Interlinking Top Rail Gasket
for 12 mm Toughened Glass
JET/Gasket 12/2.9

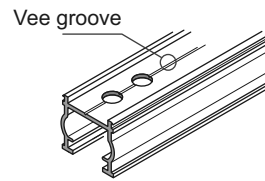

Interlinking Top Rail Gasket
for 15 mm Toughened Glass
JET /Gasket 15/2.9

1 - 12, 15mm Glass and Gasket

Application Notes:

- Cut short lengths of Gasket (50mm) and place say every 700mm.
- Cut/adjust Interlinking rail to correct dimensions, test in place.
- Remove all, install full cut lengths of Gasket to glass top edge

- Assemble Top Rail + Joiners and suitable End plates
- Place blobs of V60 silicone in every Gasket hole
- Then place Top Rail extrusion + Joiners and End plates in place clipping firmly to Gasket
- Tape all down, wait 24 hrs to fully bond. Clean up.

Note: Ends must be attached to structure or post,
- Joins must have a suitable joiner plate

12mm Glass and Gasket shown

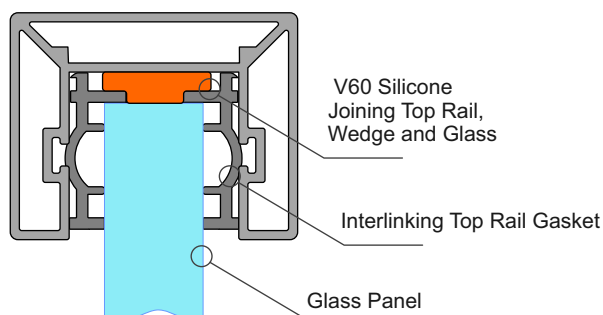

2 - End Plate Brackets

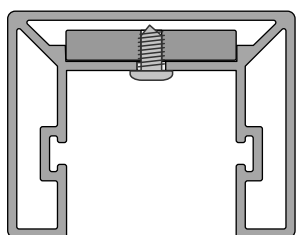

End Plate
Tabs all 22.5 x 4mm SS.

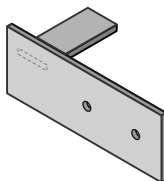

Interlinking Top Rail
Wall type End Plate
SS. 120x45mm
JET 40LH

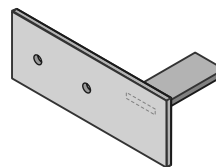

Interlinking Top Rail
Wall type End Plate
SS. 120x45mm
JET 40RH

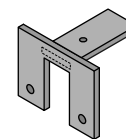

Interlinking Top Rail
End Bracket
SS. 60mm x 46mm
JET 42

(After cutting extrusions to length) - With End Plate in place, spot drill from below for position -
- Drill out to SS tab to 3mm dia, extrusion to 4mm dia - Use No 6 x 1/4in SS ST Pan sq drive Screw,
@ 2 per plate - End Plate must be securely attached to Post or structure.

3 - Joiners

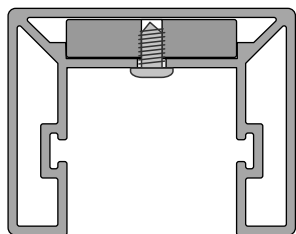

Joiners
22.5 x 5mm Aluminium

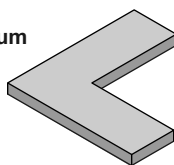

Interlinking Top Rail
Corner Joiner
75x75x5mm
JET 31

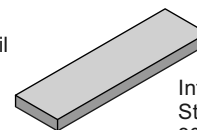

Interlinking Top Rail
Straight Joiner
80x22.8x5mm
JET 30

(After cutting extrusions to length) - With Joiner in place, spot drill from below for position
- Drill out to Joiner to 3mm dia, extrusion to 4mm dia
- Use No 6 x 1/4in SS ST Pan sq drive Screw, @ 2 per plate

Important Note: All Interlinking rails, at their ends must be attached to a Building Structure or to an Edge Post attached to the Deck structure, using Rail End Plates/Brackets



Juralco 38mm Rectangular Interlinking Top Rail

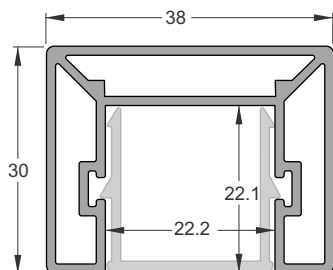

Rectangular Interlinking Top Rail
JET/220/5.8
Also showing Infill Clip, for
use in between Glass Panels

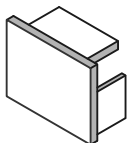

Interlinking Top
Rail End Cap
JET 37

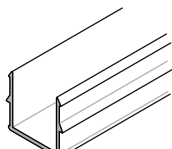

Infill Clip
Part No JET/215/5.8

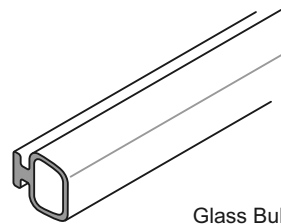

Glass Bulb Seal
Part No JET/IB/CVRBLB250

This Page applies to 15.2mm and 17.2mm Laminated Safety Glass only

1 - 15.2, 17.2mm Glass and Gasket

Application Notes:

- Assemble Top Rail + Joiners and suitable End plates
- Place Full lengths of Bulb seal in place.
- Place blobs of V60 silicone along top edge of Glass at similar spacings to Gasket on previous page.
- Then place Top Rail extrusion and bulb seals firmly onto Glass.
- Tape all down, wait 24 hrs to fully bond. Clean up.

Note: Ends must be attached to structure or post,
- Joins must have a suitable joiner plate

15.2mm Glass and Gasket shown

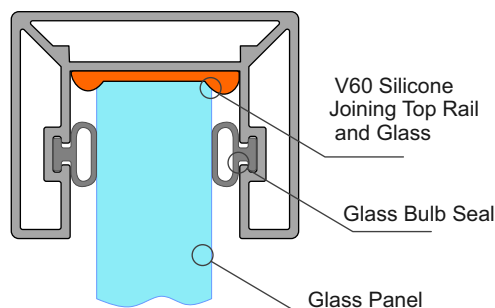

2 - End Plate Brackets

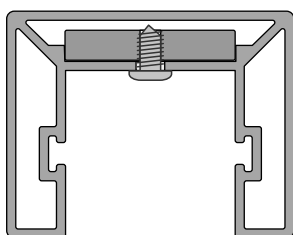

End Plate
Tabs all 22.5 x 4mm SS.

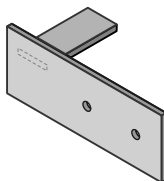

Interlinking Top Rail
Wall type End Plate
SS. 120x45mm
JET 40LH

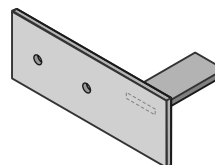

Interlinking Top Rail
Wall type End Plate
SS. 120x45mm
JET 40RH

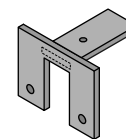

Interlinking Top Rail
End Bracket
SS. 60mm x 46mm
JET 42

(After cutting extrusions to length) - With End Plate in place, spot drill from below for position - Drill out to SS tab to 3mm dia, extrusion to 4mm dia - Use No 6 x 1/4in SS ST Pan sq drive Screw, @ 2 per plate - End Plate must be securely attached to Post or structure.

3 - Joiners

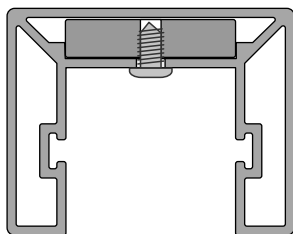

Joiners
22.5 x 5mm Aluminium

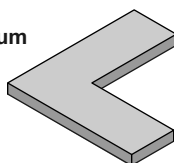

Interlinking Top Rail
Corner Joiner
75x75x5mm
JET 31

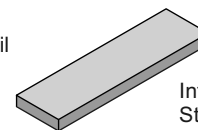

Interlinking Top Rail
Straight Joiner
80x22.8x5mm
JET 30

(After cutting extrusions to length) - With Joiner in place, spot drill from below for position - Drill out to Joiner to 3mm dia, extrusion to 4mm dia - Use No 6 x 1/4in SS ST Pan sq drive Screw, @ 2 per plate

Important Note: All Interlinking rails, at their ends must be attached to a Building Structure or to an Edge Post attached to the Deck structure, using Rail End Plates/Brackets

38mm Rectangular Interlinking Top Rail - Corner Connectors and Joiners

1 - Connectors

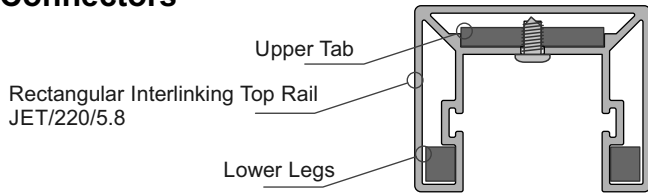

Rectangular Interlinking Top Rail
JET/220/5.8

- Swivel Kits: (After cutting extrusions to length)
- With Swivel in place, spot drill from below for position
 - Drill out Swivel to 3mm dia, extrusion to 4mm dia
 - Use No6 x 1/4in SS ST Pan sq drive screws, 2 x ea side of joint
 - Both sides must be attached.
 - Join together with the M6 x 25 C/S SS Screw

Interlinking Top Rail
Horizontal Fixed
90 deg Connector
JET 45A

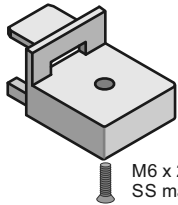

M6 x 25 C/S
SS machine screw

Interlinking Top Rail
Horizontal Fixed
90 deg Connector
JET 45B

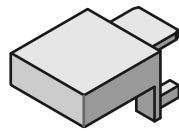

Rectangular Interlinking Top Rail
Horizontal Fixed 90deg Kit
JET220/90deg Corner Kit
(JET 45A and B + screw)

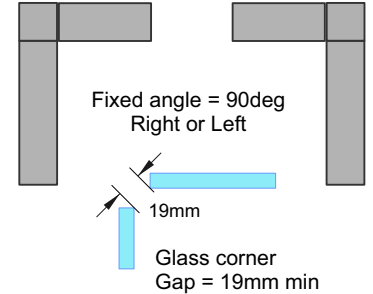
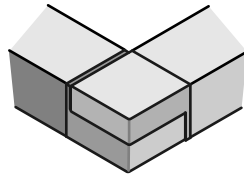

Interlinking Top Rail
Horizontal 0 - 90deg
Swivel Connector
JET 46A

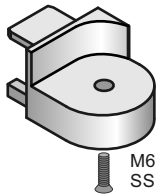

M6 x 25 C/S
SS machine screw

Interlinking Top Rail
Horizontal 0 - 90deg
Swivel Connector
JET 46B

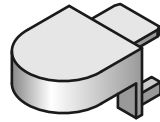

Rectangular Interlinking Top Rail
Horizontal 0 - 90 deg Right/Left
Swivel Connector Kit
JET220/Horizontal Adj Corner Kit
(JET 46A and B + screw)

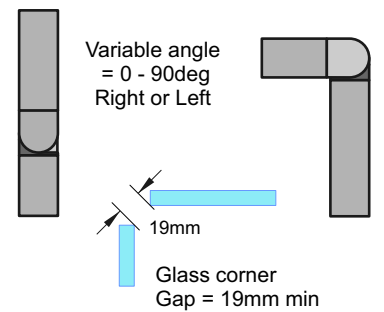
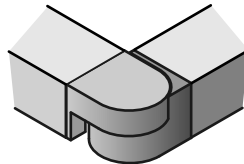

Interlinking Top Rail
Vertical 35deg up
to 35 deg down
Swivel Connector
JET 47A

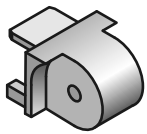

M6 x 25 C/S
SS machine screw

Interlinking Top Rail
Vertical 35deg up
to 35 deg down
Swivel Connector
JET 47B

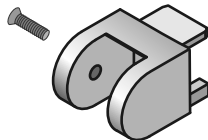

Interlinking Top Rail Vertical 35deg up
to 35 deg down. Swivel Connector Kit
JET220/Vertical Adj Corner Kit
(JET 47A and B + screw)

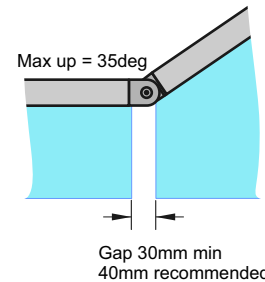
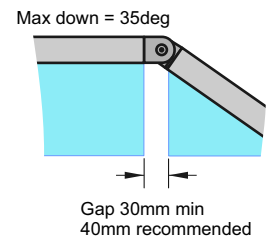
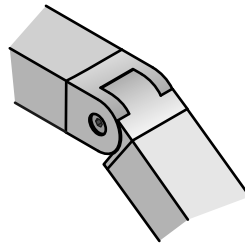

2 - Joiners

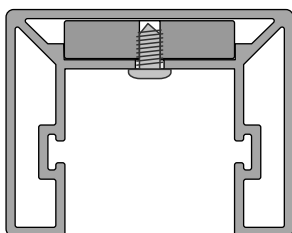

- Joiners: (After cutting extrusions to length)
- With Joiner in place, spot drill from below for position
 - Drill out to joiner to 3mm dia, extrusion to 4mm dia
 - Use No 6 x 1/4in SS ST Pan sq drive screws, 2 x ea side of joint
 - Both ends must be attached.
 - Joins, where required must be at the end of Glass Panels

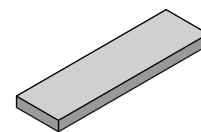

Interlinking Top Rail
Straight Joiner
80x22.8x5mm
JET 30

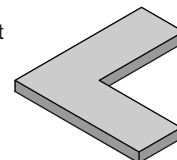

Interlinking Top Rail
Corner Joiner
75x75x5mm
JET 31

Joiners both 22.5 x 5mm Aluminium

Juralco 50mm Round Interlinking Top Rail

This page applies to 12mm and 15mm Toughened Glass only

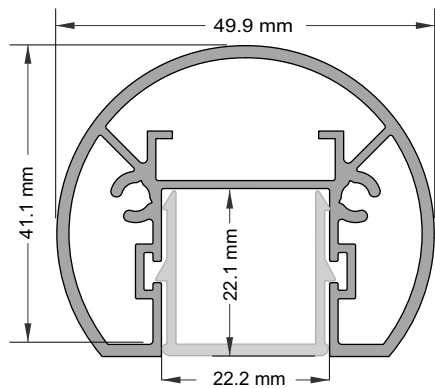

Round Interlinking Top Rail
JET/211/5.8
Also showing Infill Clip, for
use in between Glass Panels

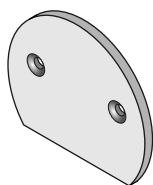

Round Interlinking
Top Rail End Cap
JET/231

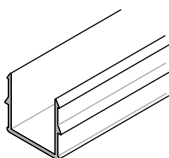

Infill Clip
Part No JET/215/5.8

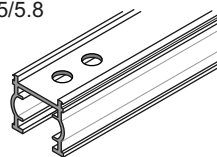

Interlinking Top Rail Gasket
for 12 mm Toughened Glass
JET /Gasket 12/2.9

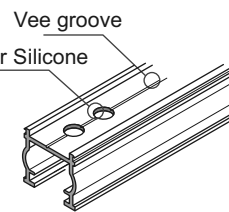

Interlinking Top Rail Gasket
for 15 mm Toughened Glass
JET /Gasket 15/2.9

1 - 12, 15mm Glass and Gasket

Application Notes:

- Cut short lengths of Gasket (50mm) and place say every 700mm.
- Cut/adjust Interlinking rail to correct dimensions, test in place.
- Remove all, install full cut lengths of Gasket to glass top edge
- Assemble Top Rail + Joiners and suitable End plates
- Place blobs of V60 silicone in every Gasket hole
- Then place Top Rail extrusion + Joiners and End plates in place clipping firmly to Gasket
- Tape all down, wait 24 hrs to fully bond. Clean up.

Note: Ends must be attached to structure or post,
- Joins must have a suitable joiner plate

12mm Glass and Gasket shown

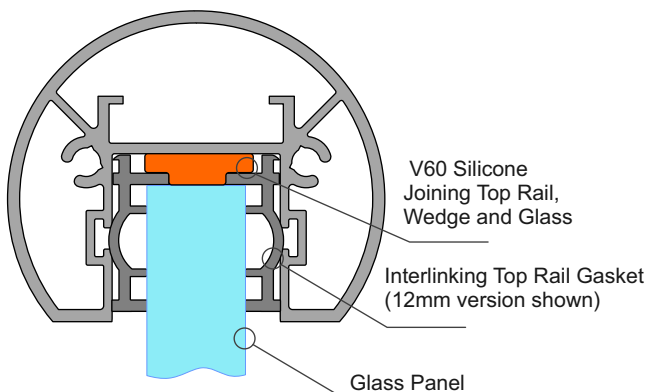

2 - End Plate Brackets

End Plate
Tabs all 22.5 x 4mm SS.

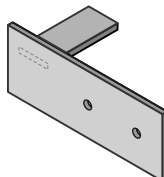
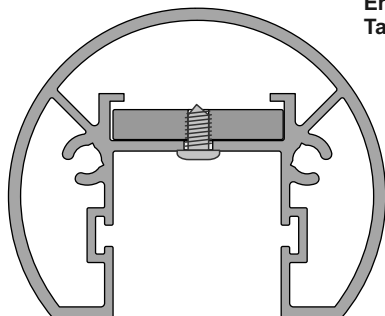

Interlinking Top Rail
Wall type End Plate
SS. 120x45mm
JET 40LH

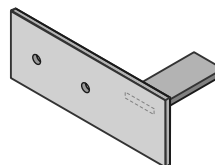

Interlinking Top Rail
Wall type End Plate
SS. 120x45mm
JET 40RH

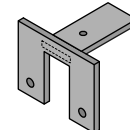

Interlinking Top Rail
End Bracket
SS. 60mm x 46mm
JET 42

(After cutting extrusions to length) - With End Plate in place, spot drill from below for position
- Drill out to SS tab to 3mm dia, extrusion to 4mm dia - Use No 6 x 1/4in SS ST Pan sq drive Screw,
@ 2 per plate - End Plate must be securely attached to Post or structure.

3 - Joiners

Joiners
22.5 x 5mm Aluminium

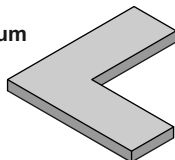
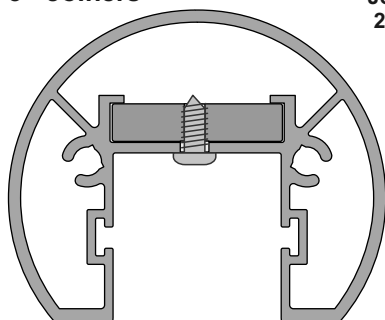

Interlinking Top Rail
Corner Joiner
75x75x5mm
JET 31

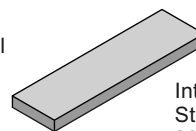

Interlinking Top Rail
Straight Joiner
80x22.8x5mm
JET 30

(After cutting extrusions to length) - With Joiner in place, spot drill from below for position
- Drill out to Joiner to 3mm dia, extrusion to 4mm dia
- Use No 6 x 1/4in SS ST Pan sq drive Screw, @ 2 per plate

Important Note: All Interlinking rails, at their ends must be attached to a Building Structure or to an Edge Post attached to the Deck structure, using Rail End Plates/Brackets



Juralco 50mm Round Interlinking Top Rail

This Page applies to 15.2mm and 17.2mm Laminated Safety Glass only

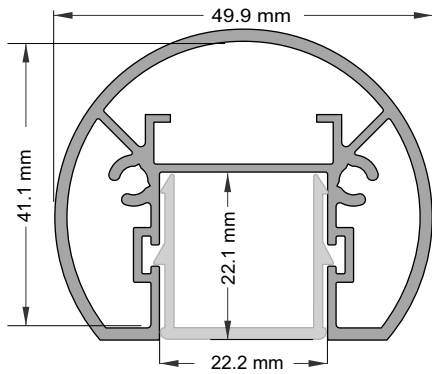

Round Interlinking Top Rail
JET/211/5.8
Also showing Infill Clip, for use in between Glass Panels

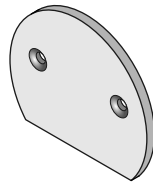

Round Interlinking Top Rail End Cap
JET 231

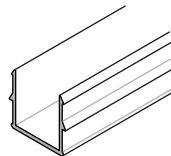

Infill Clip
JET/215/5.8

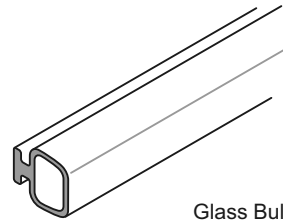

Glass Bulb Seal
JET/IB/CVRBLB250

1 - 15.2, 17.2mm Glass and Gasket

15.2mm Glass and Gasket shown

Application Notes:

- Assemble Top Rail + Joiners and suitable End plates
- Place Full lengths of Bulb seal in place.
- Place blobs of V60 silicone along top edge of Glass at similar spacings to Gasket on previous page.
- Then place Top Rail extrusion and bulb seals firmly onto Glass.
- Tape all down, wait 24 hrs to fully bond. Clean up.

Note: Ends must be attached to structure or post,
- Joins must have a suitable joiner plate

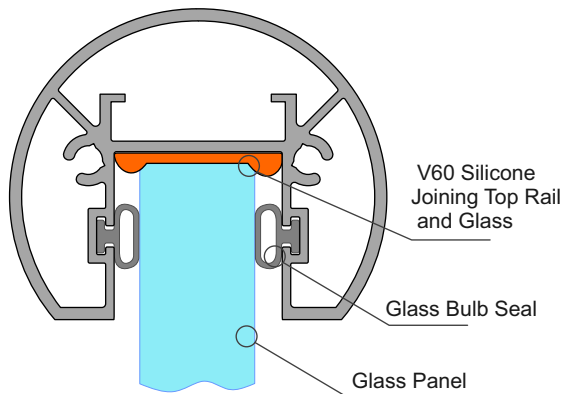

2 - End Plate Brackets

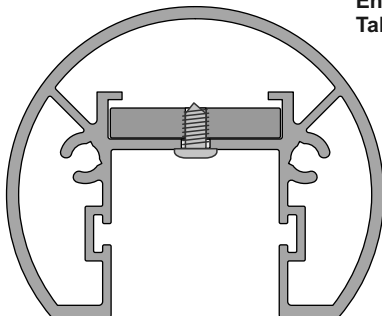

End Plate
Tabs all 22.5 x 4mm SS.

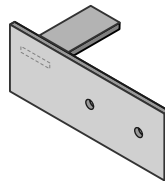

Interlinking Top Rail
Wall type End Plate
SS. 120x45mm
JET 40LH

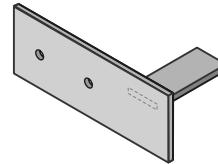

Interlinking Top Rail
Wall type End Plate
SS. 120x45mm
JET 40RH

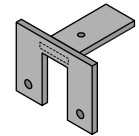

Interlinking Top Rail
End Bracket
SS. 60mm x 46mm
JET 42

(After cutting extrusions to length) - With End Plate in place, spot drill from below for position
- Drill out to SS tab to 3mm dia, extrusion to 4mm dia - Use No 6 x 1/4in SS ST Pan sq drive Screw,
@ 2 per plate - End Plate must be securely attached to Post or structure.

3 - Joiners

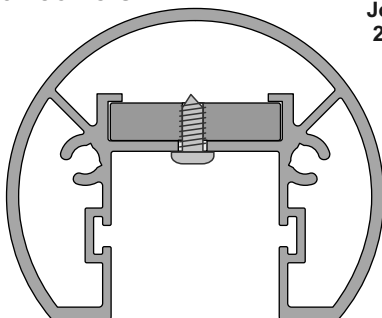

Joiners
22.5 x 5mm Aluminium

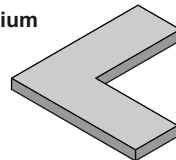

Interlinking Top Rail
Corner Joiner
75x75x5mm
JET 31

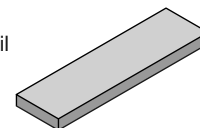

Interlinking Top Rail
Straight Joiner
80x22.8x5mm
JET 30

(After cutting extrusions to length) - With Joiner in place, spot drill from below for position
- Drill out to Joiner to 3mm dia, extrusion to 4mm dia
- Use No 6 x 1/4in SS ST Pan sq drive Screw, @ 2 per plate

Important Note: All Interlinking rails, at their ends must be attached to a Building Structure or to an Edge Post attached to the Deck structure, using Rail End Plates/Brackets

38mm Rectangular and 50mm Round Interlinking Top Rail - End Bracket Attachments

Applies to 38mm Rectangular and 50mm Round Interlinking Top Rails only

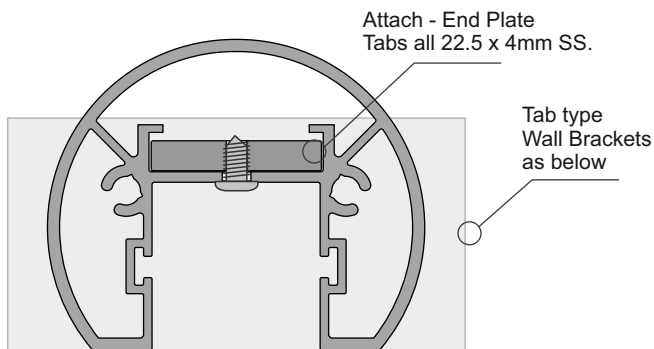

Round Interlinking Top Rail Extrusion
JET/211/5.8

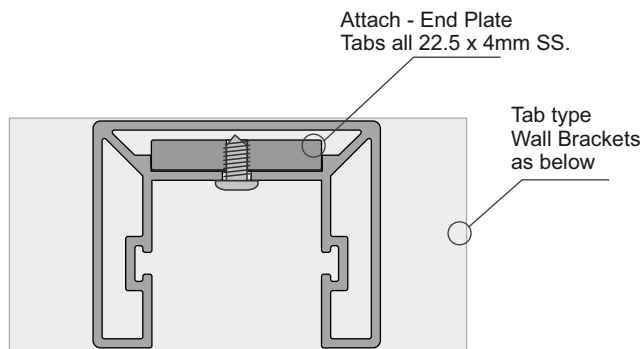

Interlinking Top Rail Extrusion
JET/220/5.8

Interlinking Top Rail End Bracket Options - Both types above - Tab attach Type

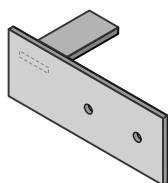

Interlinking Top Rail
Wall type End Plate
SS. 120x45mm
JET 40LH

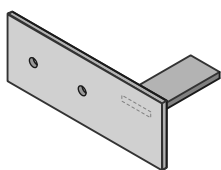

Interlinking Top Rail
Wall type End Plate
SS. 120x45mm
JET 40RH

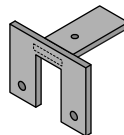

Interlinking Top Rail
End Bracket
SS. 60mm x 46mm
JET 42

Tabs all 22.5 x 4mm SS.
Front faces all 3mm SS

Interlinking Top Rail End Bracket Options - Round Type only - Attach into Screw ports

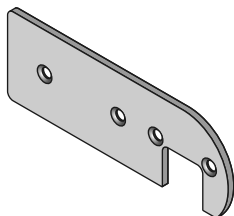

Interlinking Top Rail
Wall type offset End Plate
50mm Round Rail type only
120x42x3mm, Al
C/s both sides = RH or LH
JET 233



Interlinking Top Rail
Wall type End Plate
50mm Round Rail type only
50x58x5mm, Al
JET 232

General Notes:

- All fixings to be Stainless Steel - PVC Tape layer between Structure and Bracket
- ULS Point load $N^* = 0.9kN$, inwards, outwards or down and in tension

Note : Fixing to Steel

- use 2 off 8g SS TEK Screws or M6 SS Bolts
- Steel 2mm min thickness
- Steel 300MPa minimum
- 15mm min distance to any Edges

Note : Fixing to Timber Wall

- use 2 off 8g SS Screws, 35mm min into studs.
- use Sika Supergrip 2hr
- 30mm min distance to Horizontal Edge
- If Weatherboard use suitable predrilled Wedge
- Timber stud wall to be designed and detailed in accordance with NZ3603 or NZ3604

Note : Fixing to Juralco EDGE Post

- use 2 off 8g x 25 SS PK Screws

Note : Fixing to Concrete Wall

- use 2 off M6 x70 SS Screw Anchors
- Solid Concrete min 20Mpa
- Block wall Concrete filled/Reinforced
- 140mm min Wall thickness
- 70mm min distance to Horizontal Edge
- 100mm min distance to Vertical Edge
- Blockwork wall must be corefilled /reinforced and is to be designed and detailed in accordance with NZ4230 or NZ4229

Important Note: All Interlinking rails, at their ends must be attached to a Building Structure or to an Edge Post attached to the Deck structure, using Rail End Plates/Brackets



25mm SS Interlinking Top Rail

This page applies to 12mm Toughened Glass only

Small SS Interlinking Top Rail

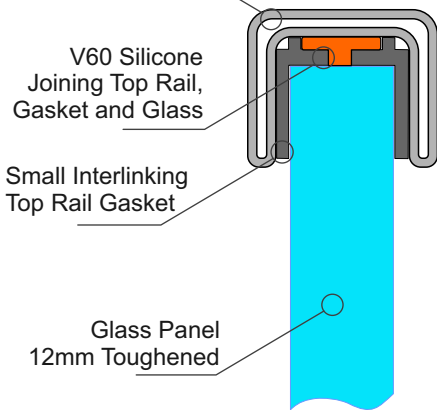

25mm SS Interlinking Top Rail

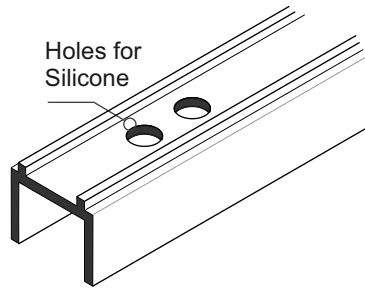

SMALL SS INTERLINKING TOP RAIL GASKET
JET/490GT/12/2.9 (Black)

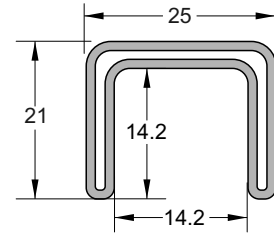

SMALL SS INTERLINKING TOP RAIL
JET/490/5.8/SSS JET/490/5.8/SCC
Duplex 2205

25mm SS Interlinking Rail Connections

Note : All these Brackets use M5 x 6 SS Grub Screws.
If necessary these holes must be Drilled + tapped M5, as shown.
The under side of the Interlinking Rail must be drilled M6 to match M5 tapped holes positions, for access to Grub screws
- Joins, where required must be at the end of Glass Panels
Available as Satin(SSS) or Powdercoated SCC finishes

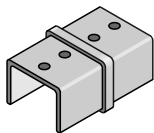
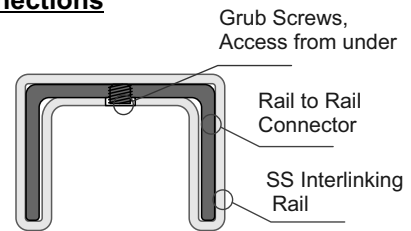

180deg INLINE JOINER
Duplex 2205
JET491/SSS JET491/SCC
21mm x 25mm x 51mm deep

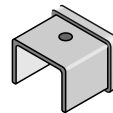

END CAP Duplex 2205
JET492/SSS JET492/SCC
21mm x 25mm x 25mm deep

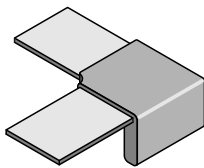

90deg JOINER Duplex 2205
JET493/SSS JET493/SCC
21mm x 80mm x 80mm

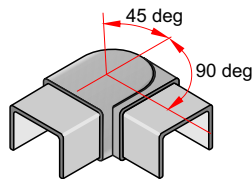

+90 to - 45 deg ADJUSTABLE HORIZONTAL JOINER Duplex 2205
JET494/SSS JET494/SCC
21mm x 25mm x 75mm overall deep

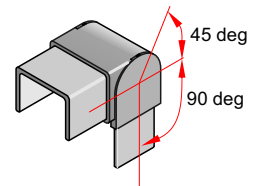

+90 to - 45 deg ADJUSTABLE VERTICAL JOINER Duplex 2205
JET495/SSS JET495/SCC
21mm x 25mm x 73mm overall deep

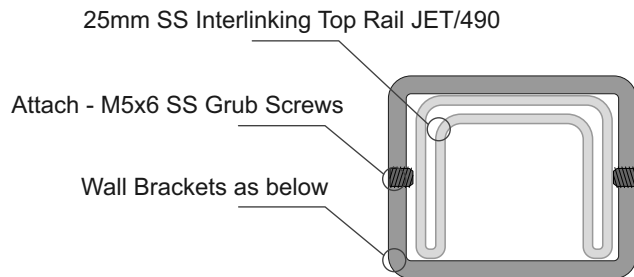

Brackets for Fixing to Wall or End Post for 25mm SS Interlinking Rail

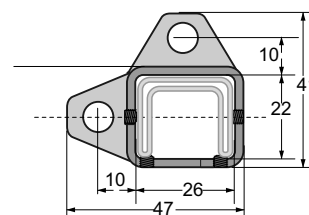
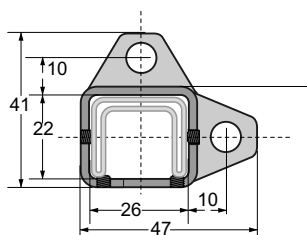
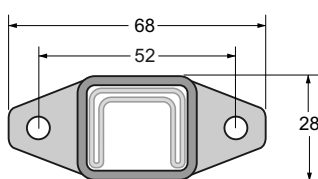

Note : All these Brackets use M5x6mm SS Grub Screws

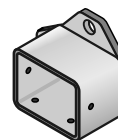
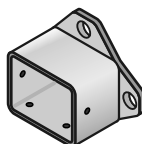
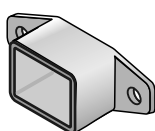

WALL BRACKET Duplex 2205
JET496/SSS JET/496/SSC
68mm x 28mm x 30mm deep

WALL BRACKET - RH Duplex 2205
JET497/RH/SSS JET497/RH/SSC
41mm x 47mm x 30mm deep

WALL BRACKET - LH Duplex 2205
JET497/LH/SSS JET497/RH/SSC
41mm x 47mm x 30mm deep

General Notes:

- All fixings to be Stainless Steel. - PVC Tape layer between Structure and Bracket
- ULS Point load $N^* = 0.9kN$, inwards, outwards or down and in tension

Note : Fixing to Steel

- use 2 off 8g SS TEK Screws or M6 SS Bolts
- Steel 2mm min thickness
- Steel 300MPa minimum
- 15mm min distance to any Edges

Note : Fixing to Timber Wall

- use 2 off 8g SS Screws, 35mm min into studs.
- use Sika Supergrip 2hr
- 30mm min distance to Horizontal Edge
- If Weatherboard use suitable predrilled Wedge
- Timber stud wall to be designed and detailed in accordance with NZ3603 or NZ3604

Note : Fixing to Juralco EDGE Post

- use 2 off 8g x 25 SS PK Screws

Note : Fixing to Concrete Wall

- use 2 off M6 x70 SS Screw Anchors
- Solid Concrete min 20Mpa
- Block wall Concrete filled/Reinforced
- 140mm min Wall thickness
- 70mm min distance to Horizontal Edge
- 100mm min distance to Vertical Edge
- Blockwork wall must be corefilled /reinforced and is to be designed and detailed in accordance with NZ4230 or NZ4229

Important Note: All Interlinking rails, at their ends must be attached to a Building Structure or to an Edge Post attached to the Deck structure, using Rail End Plates/Brackets

40mm SS Interlinking Top Rail

This page applies to 12mm and 15mm Toughened Glass and 15.2mm and 17.2mm Laminated Glass only

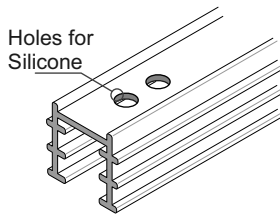

SS Interlinking Top Rail
12mm Glass Gasket
JET/430GT/12/2.9

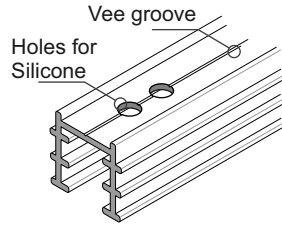

SS Interlinking Top Rail
15mm Glass Gasket
JET/430GT/15/2.9

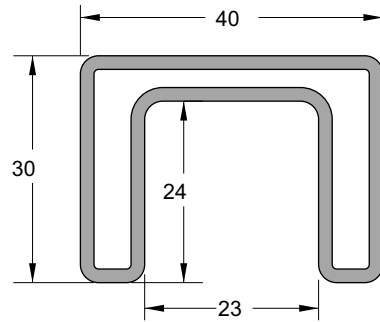

SS INTERLINKING TOP RAIL
JET/430/PSS/5.8

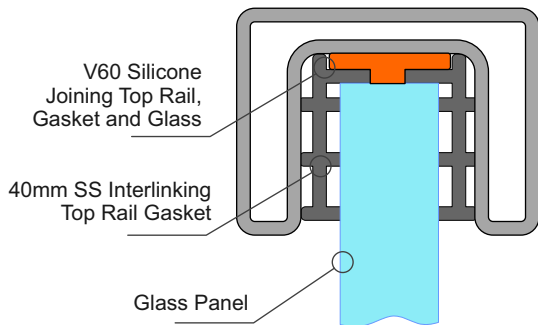

Use Gasket for 12mm and 15mm Toughened Glass

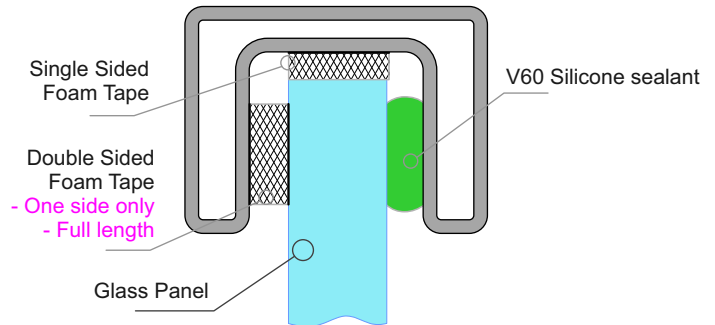

Use Foam Tape for 15.2mm and 17.2mm Laminated Glass

40mm SS Interlinking Rail Connectors

Note : All these Brackets use M5 x 6 SS Grub Screws.
If necessary these holes must be Drilled + tapped M5, as shown.
The under side of the Interlinking Rail must be drilled M6/7 to match M5 tapped holes positions, for access to Grub screws
- Joins, where required must be at the end of Glass Panels

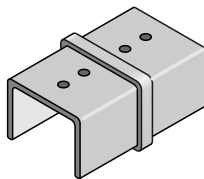
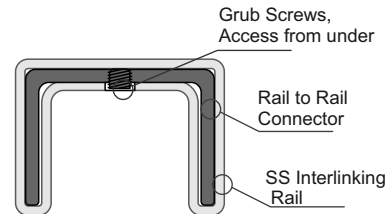

180deg INLINE JOINER 2205
JET/431/PSS
60mm x 40mm x 30mm deep

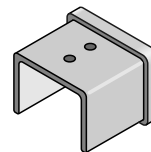

END CAP 2205
JET/432/PSS
33mm x 40mm x 30mm deep

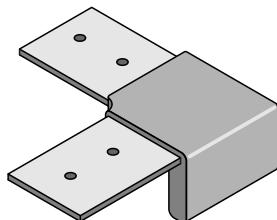

90deg JOINER 2205
JET/433/PSS
95mm x 95mm x 30mm deep

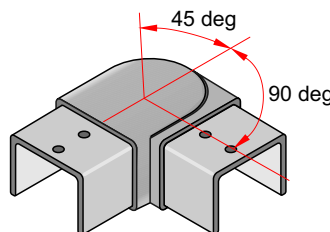

+90 to - 45 deg ADJUSTABLE
HORIZONTAL JOINER 2205
JET/434/PSS
70mm x 70mm x 30mm deep

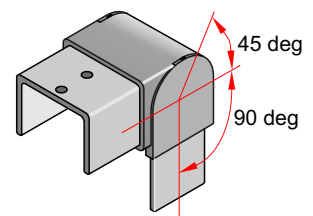

+90 to - 45 deg ADJUSTABLE
VERTICAL JOINER 2205
JET/435/PSS
60mm x 60mm x 40mm wide

40mm SS Interlinking Top Rail - End Brackets

This page applies to 12mm and 15mm Toughened Glass and 15.2mm and 17.2mm Laminated Glass only

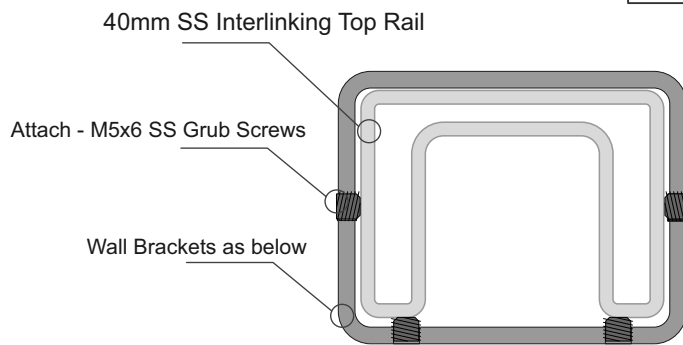

SS INTERLINKING TOP RAIL
Part No JET/430/PSS/5.8

Brackets for Fixing to Wall or End Post for 40mm SS Interlinking Rail

Note : All these Brackets use M5 x 8mm SS Grub Screws

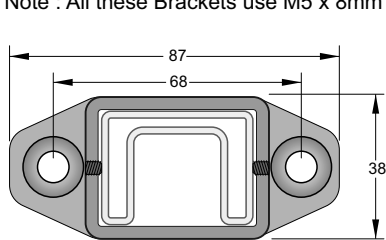

WALL BRACKET 2 FIX 2205
Part No JET/436/PSS
87mm x 37mm x 25mm deep

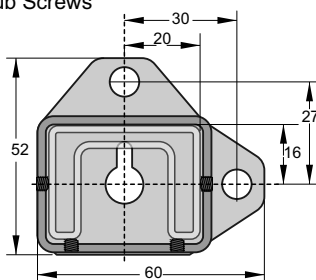

WALL BRACKET 2 FIX - RH 2205
Part No JET/437/RH/PSS
52mm x 60mm x 33mm deep

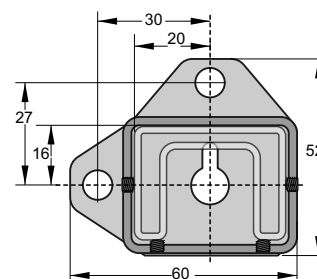

WALL BRACKET 2 FIX - LH 2205
Part No JET/437/LH/PSS
52mm x 60mm x 33mm deep

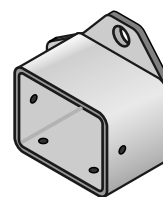
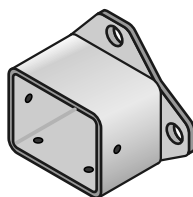
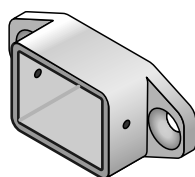

General Notes:

- All fixings to be Stainless Steel - PVC Tape layer between Structure and Bracket
- ULS Point load $N^* = 0.9\text{kN}$, inwards, outwards or down and in tension

Note : Fixing to Steel

- use 2 off 8g SS TEK Screws or M6 SS Bolts
- Steel 2mm min thickness
- Steel 300MPa minimum
- 15mm min distance to any Edges

Note : Fixing to Juralco EDGE Post

- use 2 off 8g x 25 SS PK Screws

Note : Fixing to Timber Wall

- use 2 off 8g SS Screws, 35mm min into studs.
- use Sika Supergrip 2hr
- 30mm min distance to Horizontal Edge
- If Weatherboard use suitable predrilled Wedge
- Timber stud wall to be designed and detailed in accordance with NZ3603 or NZ3604

Note : Fixing to Concrete Wall

- use 2 off M6 x70 SS Screw Anchors
- Solid Concrete min 20Mpa
- Block wall Concrete filled/Reinforced
- 140mm min Wall thickness
- 70mm min distance to Horizontal Edge
- 100mm min distance to Vertical Edge
- Blockwork wall must be corefilled /reinforced and is to be designed and detailed in accordance with NZ4230 or NZ4229

Important Note: All Interlinking rails, at their ends must be attached to a Building Structure or to an Edge Post attached to the Deck structure, using Rail End Plates/Brackets



Glass Panel Stiffener Brackets

Applies to 15.2mm Toughened Laminated Glass and 13.52mm SentryGlas.
Also for 12mm and 15mm Toughened Glass for Pool Fences alignment only

Top Edge, Frameless Glass Stiffeners.

- Install 200mm max from Glass Top edge
- Supplied as a kit, with screws, a variety of Gaskets and a SS clamp Plate
- Duplex 2205 SS construction. Polished (PSS), Satin (SSS) or Powder coat SCC Finishes

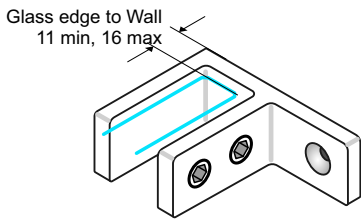

90 Deg Glass to Wall
75x505x25mm
Part No JET/72/PSS
Part No JET/72/SSS
Part No JET/72/SCC

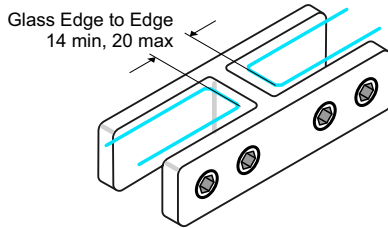

180 Deg Glass to Glass
70x34x25mm
Part No JET/71/PSS
Part No JET/71/SSS
Part No JET/71/SCC

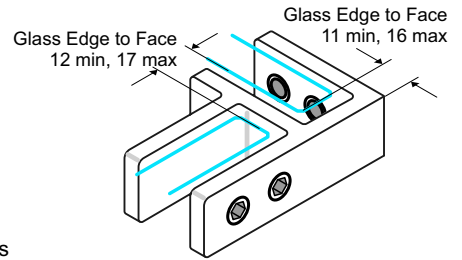

90 deg Glass to Glass
65x55x25mm
Part No JET/70/PSS
Part No JET/70/SSS
Part No JET/70/SCC

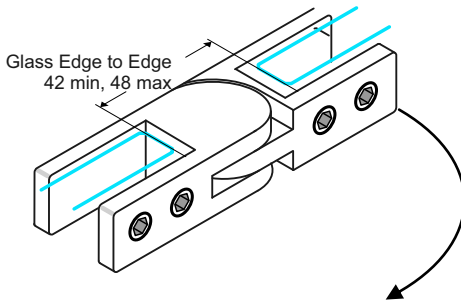

90 - 180 Deg Adjustable Glass to Glass
135x34x25mm
Part No JET/73/PSS
Part No JET/73/SSS
Part No JET/73/SCC

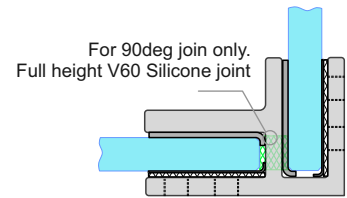

Top Edge, Frameless Glass Stiffeners.

- Install 200mm max from Glass Top edge
- Supplied as a kit, with screws, a variety of Gaskets and a SS clamp Plate
- Duplex 2205 SS construction. Polished (PSS), Satin (SSS) or Powder coat SCC Finishes

Applies to 17.2mm Toughened Laminated Glass and 17.52mm, 21.52 SentryGlas only.

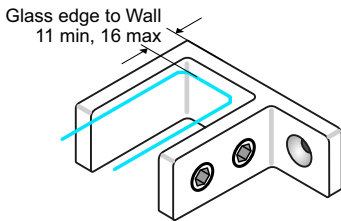

90 Deg Glass to Wall
65x55x25mm
Part No JET/82/PSS
Part No JET/82/SSS
Part No JET/82/SCC

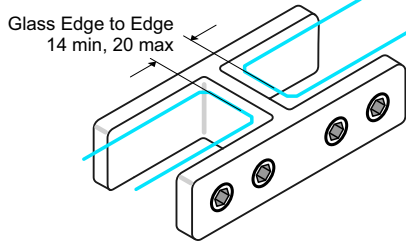

180 Deg Glass to Glass
103x39x25mm
Part No JET/81/PSS
Part No JET/81/SSS
Part No JET/81/SCC

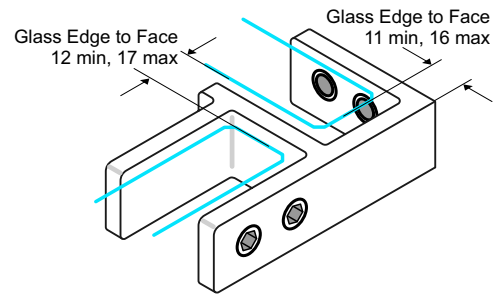

90 deg Glass to Glass
88x55x25mm
Part No JET/80/PSS
Part No JET/80/SSS
Part No JET/80/SCC

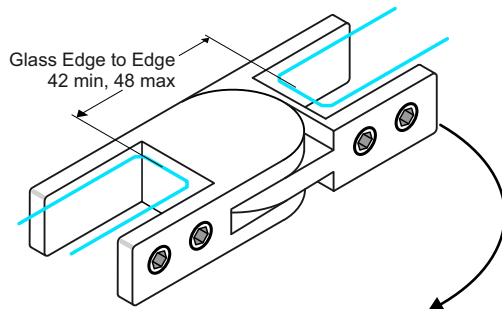

90 - 180 Deg Adjustable Glass to Glass
145x39x25mm
Part No JET/83/PSS
Part No JET/83/SSS
Part No JET/83/SCC

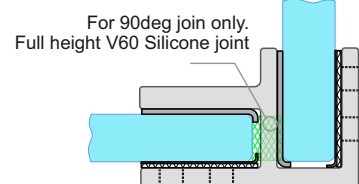

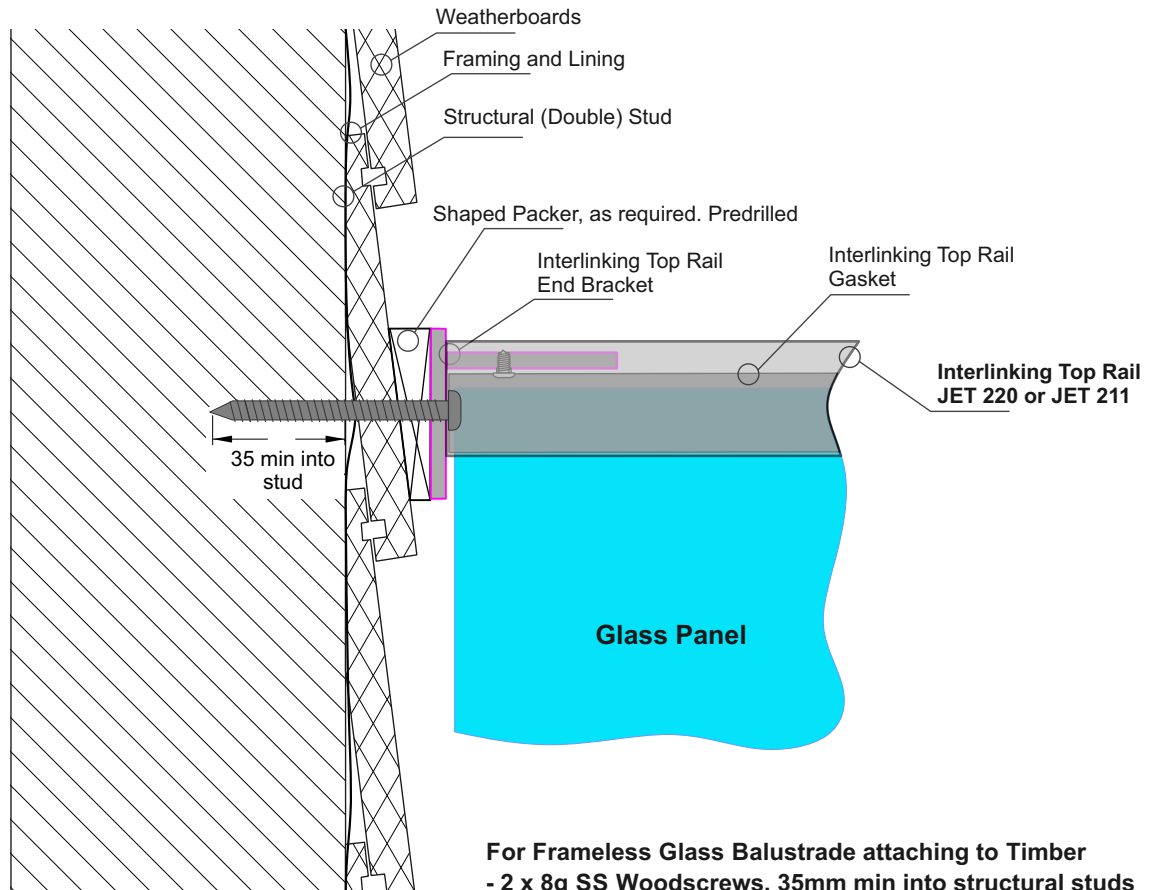

For Frameless Glass Balustrade attaching to Timber
- 2 x 8g SS Woodscrews, 35mm min into structural studs
- 20mm min to edge of stud in all directions

Interlinking Top Rail End Bracket Options - Drawing above shows JET40

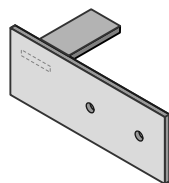

Interlinking Top Rail
Wall type End Plate
SS. 120x45mm
Part No JET 40LH

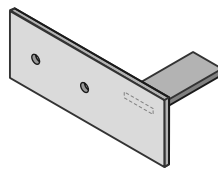

Interlinking Top Rail
Wall type End Plate
SS. 120x45mm
Part No JET 40RH

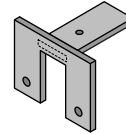

Interlinking Top Rail
End Bracket
SS. 60mm x 46mm
Part No JET 42

Notes:

- All fixings to be stainless steel
- Timber stud wall to be designed by Project structural engineer for loads imposed by Balustrade.
- ULS Point load $N^* = 0.9\text{kN}$, inwards, outwards or down.
- Minimum Stud size = 90mm x 45mm
- Minimum Timber grade = Sg8
- Timber stud wall to be designed and detailed in accordance with NZ3603 or NZ3604

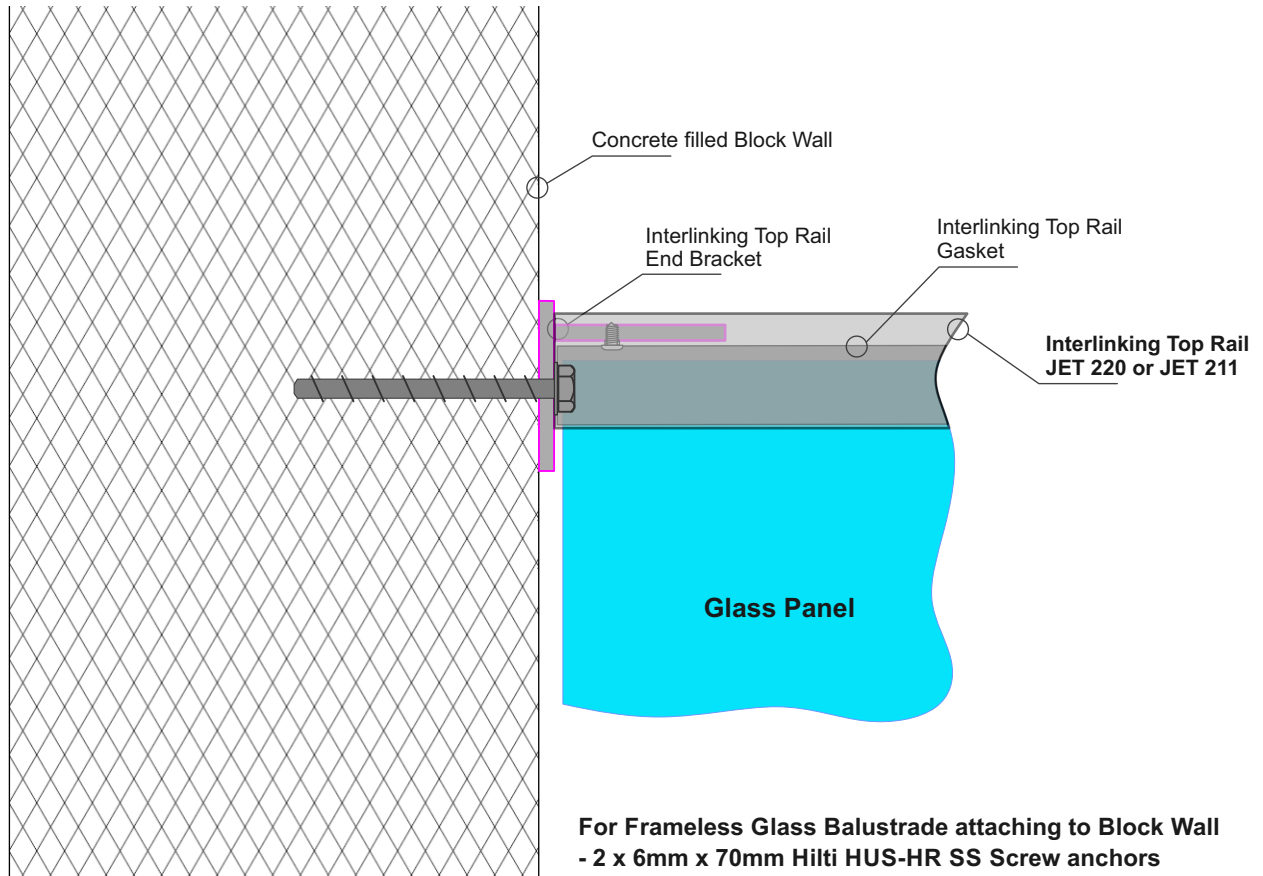

For Frameless Glass Balustrade attaching to Block Wall
 - 2 x 6mm x 70mm Hilti HUS-HR SS Screw anchors
 - For concrete drill 6mmØ holes
 - 70mm min to side edge of concrete, 100mm to top edge.

Interlinking Top Rail End Bracket Options - Drawing above shows JET40

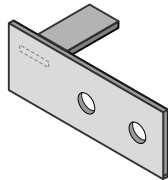

Interlinking Top Rail
 Wall type End Plate
 SS. 120x45mm
 Part No JET 40LH

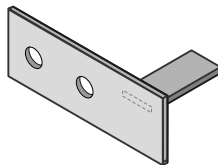

Interlinking Top Rail
 Wall type End Plate
 SS. 120x45mm
 Part No JET 40RH

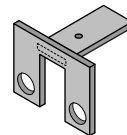

Interlinking Top Rail
 End Bracket
 SS. 60mm x 46mm
 Part No JET 42

Drill out holes to 9mmØ

Notes:

- All fixings to be stainless steel
- Blockwall to be designed by Project structural engineer for loads imposed by Balustrade.
- ULS Point load $N^* = 0.9kN$, inwards, outwards or down.
- Minimum blockwork thickness = 140mm
- Minimum core fill concrete strength = 17.5MPa
- Blockwork wall must be corefilled /reinforced and is to be designed and detailed in accordance with NZ4230 or NZ4229

Juralco Edgetec® PosiGlaze™ Balustrade System
Interlinking Top Rail for attaching to
an Edge balustrade End Post
where Wall fixing not suitable

Applies to Interlinking Top Rails suitable for 12mm or 15mm Toughened and 15.2mm or 17.2mm Laminated Glass. Not for 21.52mm SG on Timber.

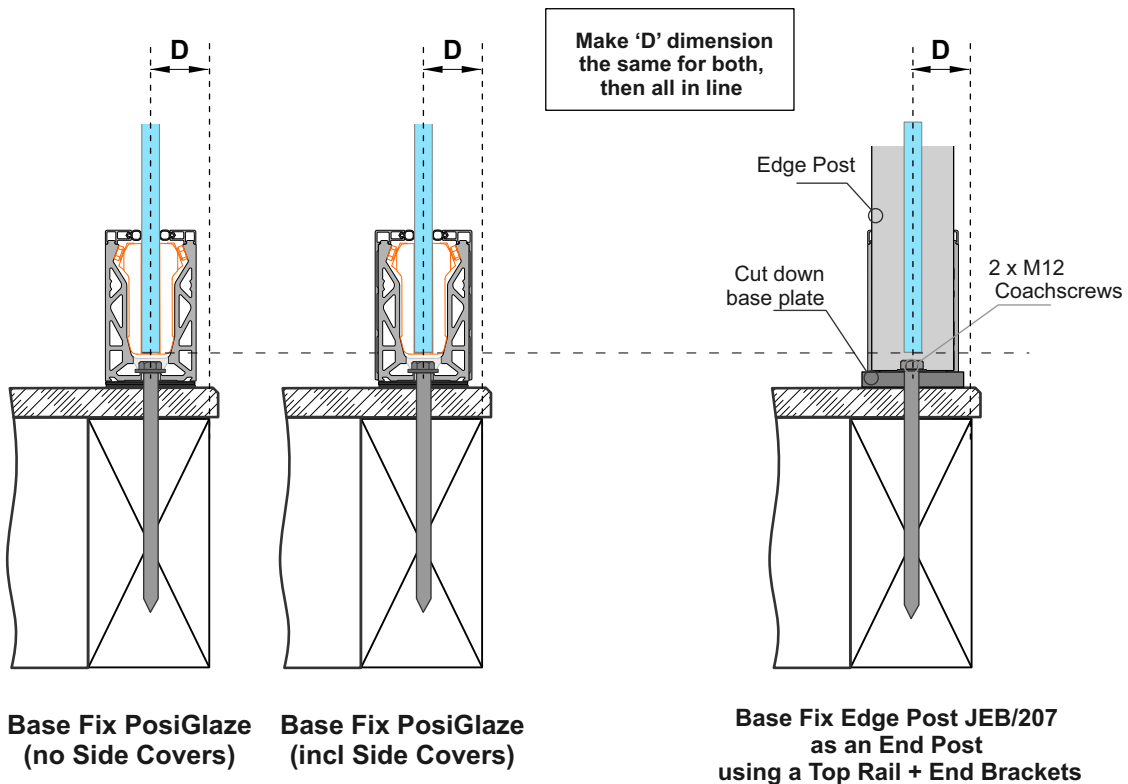
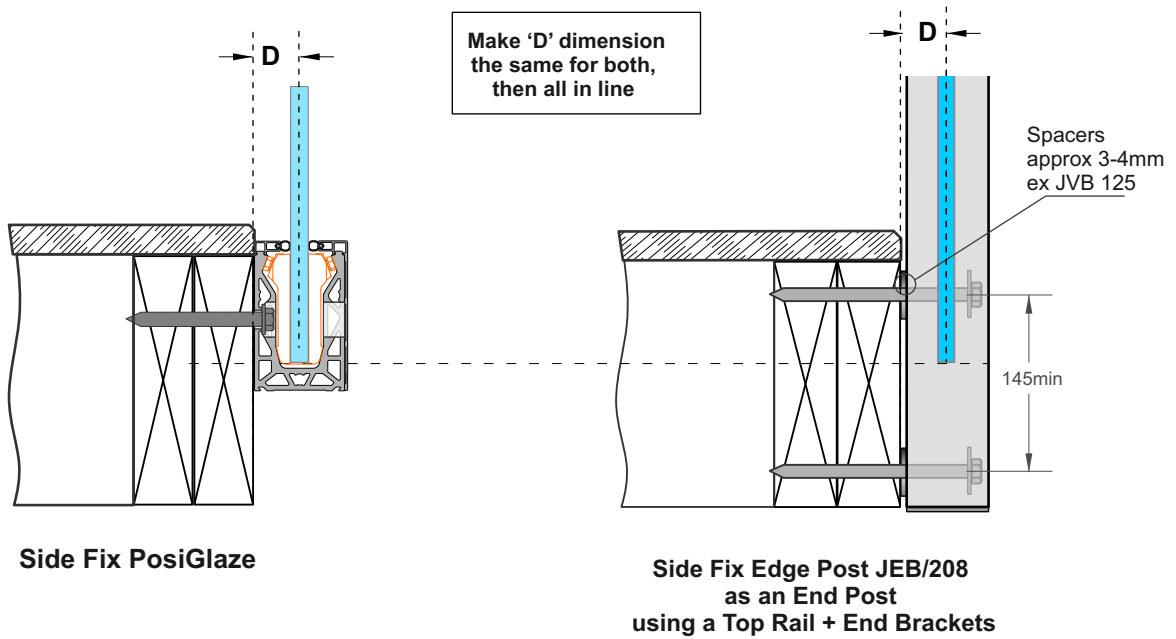

Juralco Interlinking Rails

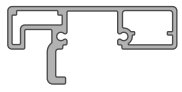

INTERLINKING RAIL
JEB/222/5.8

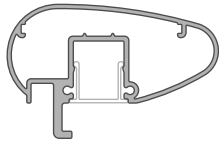

AEROFOIL HANDRAIL
JEB/217/5.8

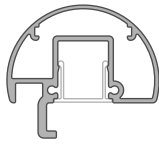

ROUND HANDRAIL
JEB/209/5.8

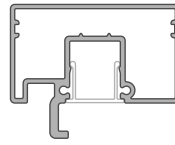

RECTANGULAR
HANDRAIL
JEB/216/5.8

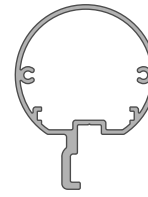

CIRCULAR
HANDRAIL
JEB/221/5.8

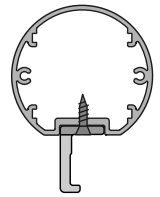

CIRCULAR
HANDRAIL
JEB/223/5.8
+ Clip JEC38

Suitable Interlinking Rail and Handrails (as Interlinking Rails)

Interlinking or Handrails on Deck side.

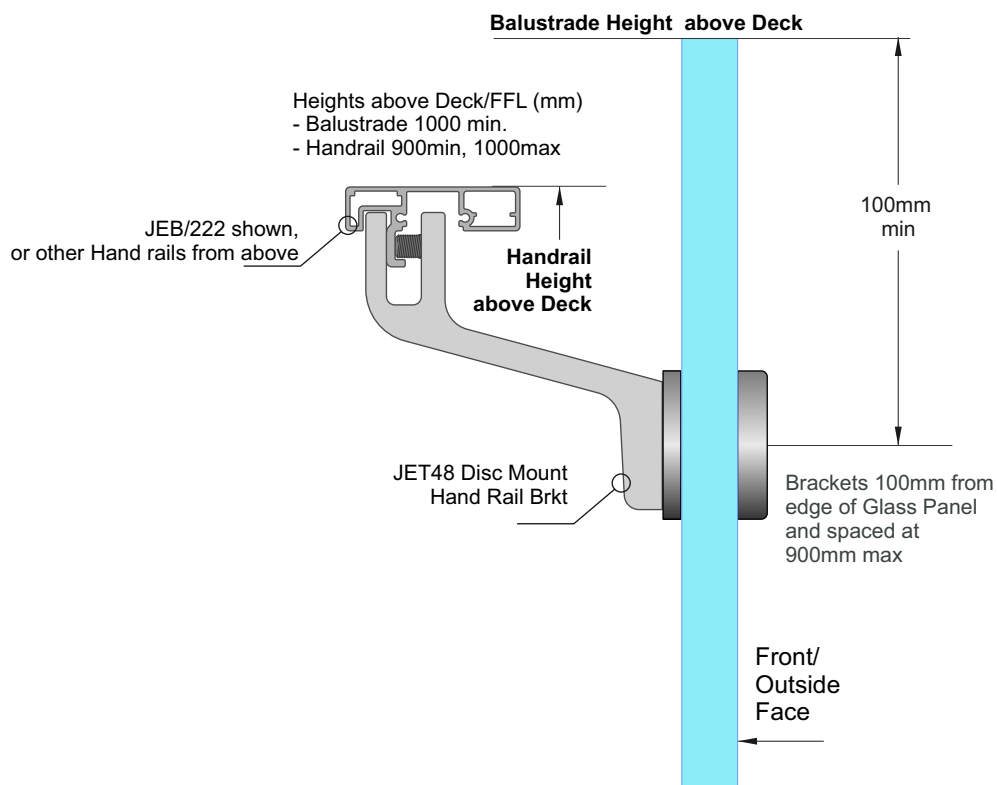

Important Note: All Interlinking rails, at their ends must be attached to a Building Structure or to an Edge Post attached to the Deck structure, using Rail End Plates/Brackets. Applies to Handrails used as Interlinking Rails

Handrail End Plates for Attaching to a Structure or Edge Deck mounted Post

End Caps for Handrails, Wall or Edge Post attach for JEB 222, 217, 209, 216 and 221 Handrails

End Caps all ex 3mm Aluminium

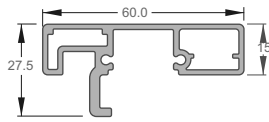

HANDRAIL
Part No JEB/222/5.8

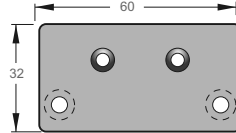

HANDRAIL
WALL ATTACH END PLATE
Part No JEC215/WC

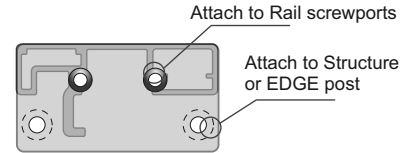

For RH and LH

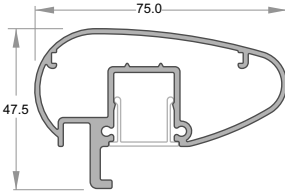

AEROFOIL HANDRAIL
Part No JEB/217/5.8

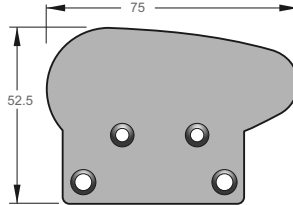

HANDRAIL
WALL ATTACH END PLATE
Part No JEC217/WC

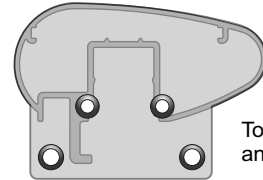

For RH and LH

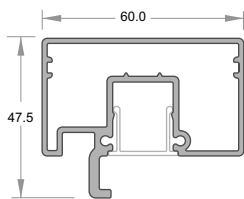

RECTANGULAR
HANDRAIL
Part No JEB/216/5.8

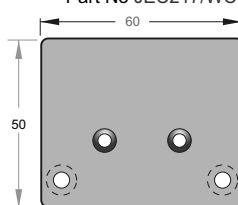

HANDRAIL
WALL ATTACH END PLATE
Part No JEC216/WC

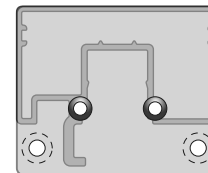

For RH and LH

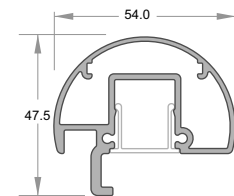

HALF ROUND HANDRAIL
Part No JEB/209/5.8

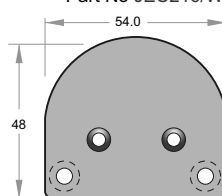

HANDRAIL
WALL ATTACH END PLATE
Part No JEC209/WC

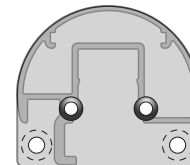

For RH and LH

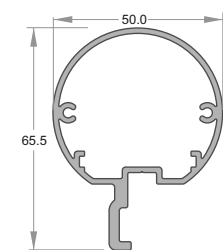

CIRCULAR HANDRAIL
Part No JEB/221/5.8

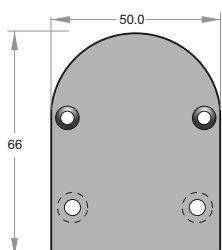

HANDRAIL
WALL ATTACH END PLATE
Part No JEC221/WC

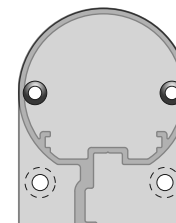

For RH and LH

General Notes: - All fixings to be Stainless Steel. - EPDM layer between Structure and End Cap
- ULS Point load $N^* = 0.9\text{kN}$, inwards, outwards or down and in tension

Note : Fixing to Steel

- use 2 off 8g SS TEK Screws or M6 SS Bolts
- Steel 2mm min thickness
- Steel 300MPa minimum
- 15mm min distance to any Edges

Note : Fixing to Juralco EDGE Post

- use 2 off 8g x 25 SS PK Screws

Note : Fixing to Timber Wall

- use 2 off 8g SS Screws, 35mm min into studs.
- use Sika Supergrip 2hr
- 30mm min distance to Horizontal Edge
- If Weatherboard use suitable predrilled Wedge
- Timber stud wall to be designed and detailed in accordance with NZ3603 or NZ3604

Note : Fixing to Concrete Wall

- use 2 off M6 x70 SS Screw Anchors
- Solid Concrete min 20Mpa
- Block wall Concrete filled/Reinforced
- 140mm min Wall thickness
- 70mm min distance to Horizontal Edge
- 100mm min distance to Vertical Edge
- Blockwork wall must be corefilled /reinforced and is to be designed and detailed in accordance with NZ4230 or NZ4229

Handrail Joiners

Rectangular Handrails and 75mm Aerofoil - End Cap, Straight and 90deg corners

All ex 3mm Aluminium

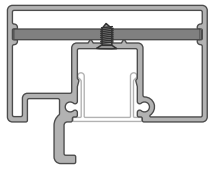

RECTANGULAR HANDRAIL
JEB/216/5.8

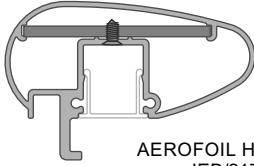

AEROFOIL HANDRAIL
JEB/217/5.8

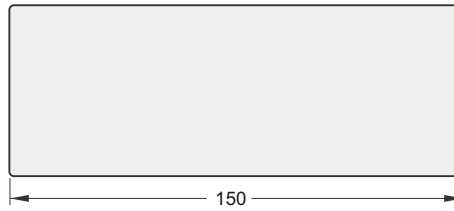

Rectangular and 75m Aerofoil Inline Joiner
Use 56.5 x 3 flat bar JA/189/5.0

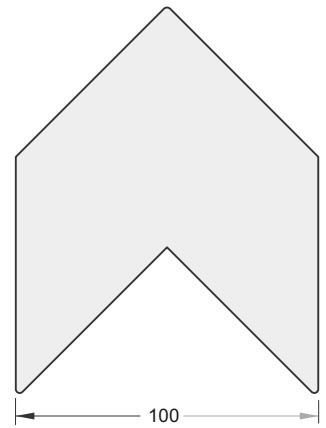

Rectangular and 75m Aerofoil 90deg Corner Joiner JEC 01

Use No6 x 1/4in SS pan sq drive screws, 2 ea side of joint

Round and Circular Handrail, End Cap, Straight and 90deg corners

All ex 3mm Aluminium

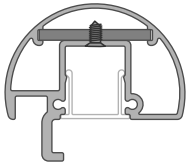

ROUND HANDRAIL
JEB/209/5.8

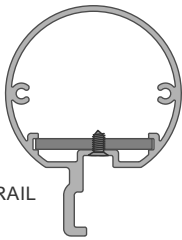

CIRCULAR HANDRAIL
JEB/221/5.8

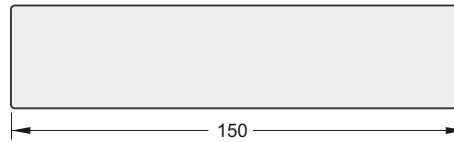

Round and Circular Inline Joiner
Use 34.0 x 3 flat bar JA/188/5.0

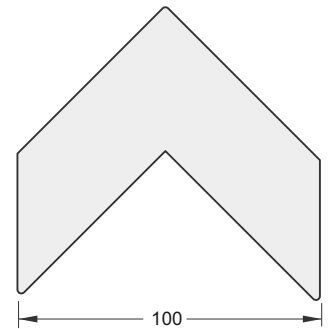

Round and Circular 90deg Corner Joiner JEC 04

Use No6 x 1/4in SS pan sq drive screws, 2 ea side of joint

Interlinking Rail End Cap, Straight 135 deg and 90deg corners

All ex 3mm Aluminium

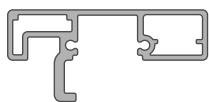

STANDARD HANDRAIL
JEB/222/5.8

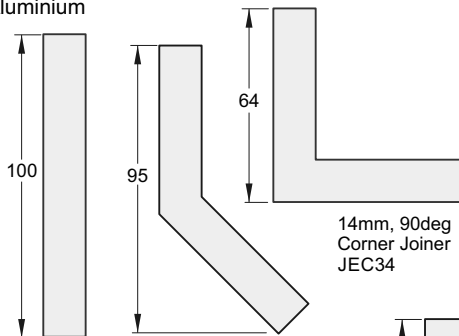
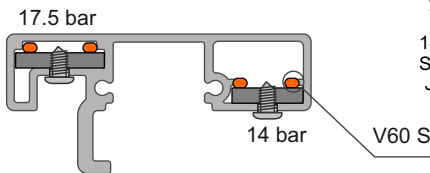

14mm Straight Joiner JEC32

14mm, 135deg Corner Joiner JEC36

14mm, 90deg Corner Joiner JEC34

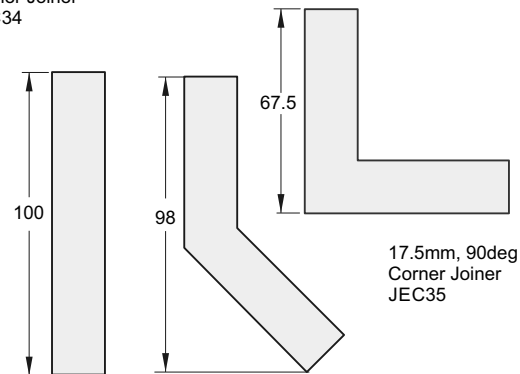

17.5mm Straight Joiner JEC33

17.5mm, 135deg Corner Joiner JEC37

17.5mm, 90deg Corner Joiner JEC35

Joiners:

- With Joiner in place, spot drill from below for position
- Drill out joiner to 3mm dia, extrusion to 4mm dia
- Use No 6 x 1/4in SS ST Pan sq drive screw
- Insert dobs of V60 Silicone inside cavities before inserting
- Both ends to be attached.
- Joins must be within 300mm of Post
- Minimum distance between screw and end of handrail is 10mm

Powder Coating Care and Maintenance

Powder Coating Installation Care

Warning re use of solvents:

- In some cases strong solvents are recommended for thinning various types of paints and also for cleaning up mastics and sealants.
- These can be harmful to the extended life of the powder coated surface, and must not be used for cleaning purposes.
- It is important to note that the damage will not be visible immediately and may take up to 12 months to develop.

If paint splashes or sealants and mastics need to be removed then the following may be safely used:
Methylated Spirits, Ethyl Alcohol, Isopropanol or preferably a mild detergent in warm water.

Joinery Protection during Installation:

All the activity on a construction site means that your powder coated items may get knocked or scratched, splattered with mortar, plaster, textured coating or paint during the later stages of construction.

Please ensure that all powder coated articles are masked or covered at this time. It is far easier to prevent accidents than to try and correct them. Should your joinery receive mortar or paint splashes see that these are removed before cure and follow the instructions contained in this brochure.

Typical sticker used to warn other trades of the need to protect and mask off powder coated joinery (applies to anodised joinery also)

"IMPORTANT ALL TRADES"
This valuable aluminium joinery will suffer permanent damage from: plaster, mortar and paint splashes - Protect if splashes occur - Immediately wash down joinery with water or meths - Do not allow splashes to harden! ~ Do not use solvents! - Do not remove this label until final clean completed.

This photograph displays damage that has occurred on site, post installation. The photo of the masked joinery displays clear signs of damage that could have occurred were it not masked. Please ensure that your joinery is protected right through the entire construction process.



Powder Coating Maintenance

External - Maintenance Program:

To extend the life of external powder coated articles and to comply with warranty requirements for powder coated aluminium joinery, a simple, regular maintenance program must be implemented.

The effects of ultra violet light, atmospheric pollution, dirt, grime and airborne salt deposits will all accumulate over time and must be removed or surface staining and weathering will occur, leading to an unsightly appearance.

For external coatings, cleaning should take place every six months. In areas where pollutants are more prevalent, such as beachfront houses and industrial or geothermal areas, then a cleaning program should be carried out on a more frequent basis ie. every one to three months.

Fences or Balustrades in close proximity to swimming pools must be washed down every six months, to clean off chlorine and salt deposits.

Cleaning your powder coating:

1. Carefully remove any loose surface deposits with a wet sponge.
2. Use a soft brush (non abrasive) and a mild household detergent (do not use solvents) in warm water, remove dust, salt and other deposits.
3. Rinse off with clean fresh water.



Restoring weathered or scratched surfaces:

Repair of Scuffed or Scratched surfaces

Dulux Spray Cans are available in all colour card colours.

Repair of Small Scratches or Chips.

Dulux Dabsticks are ideally suited for the repair of small scratches.

Dabsticks may not be available in all colour card colours.

Repair of Weathered areas .

Dulux Gloss Up is a light to medium cutting cream ideally suited for gloss restoration and has been specifically designed for this purpose. Gloss Up contains no waxes or silicone and is a one step system.



Contact Dulux Powder Coatings , ph 0064 9 441 8244

Glass Care and Maintenance

Glass Cleaning and Maintenance

Architectural glass products must be properly cleaned during the construction period so visual and aesthetic clarity are maintained. Because glass can be permanently damaged if improperly cleaned, glass producers and fabricators recommend strict compliance with the following procedures.

First, determine whether the glass is clear, tinted or reflective. Surface damage is more noticeable on reflective glass compared with the other glass products. If the reflective coated surface is exposed, either on the exterior or interior, special care must be taken when cleaning, as scratches can result in coating removal and a visible change in light transmittance. Cleaning tinted and reflective glass in direct sunlight should be avoided. Cleaning should begin at the top of the building and continue to the lower levels.

Commence cleaning by soaking the glass surfaces with clean water and a soap solution to loosen dirt or debris. Then, using a mild, non-abrasive commercial window washing solution, uniformly apply the solution to the glass surfaces with a non-abrasive applicator and follow with a squeegee to remove all of the cleaning solution from the glass surface.

Ensure that no metal parts of the cleaning equipment touch the glass surface and that no abrasive particles are trapped between the glass and the cleaning materials. All water and cleaning solution residue should be dried from the window gaskets, sealants and frames.

Scratches and Metal Scrapers

Scratches can occur from hard pointed objects or poor handling, but most often occurs from the careless removal of foreign matter from the glass surface.

Mortar splatter and paint are common offenders and efforts to remove after hardening almost always lead to surface damage. It is essential that the foreign materials are removed before they harden. Better still, if construction work continues after glazing, that the glazed areas are protected by adhesive plastic films or suitable tarpaulins or covers.

One of the common mistakes made by non-glass trades people, including glass cleaning contractors, is the use of razor blades or other metal scrapers on a large portion of the glass surface. Using large blades to scrape a window clean carries considerable risk of causing damage to the glass.

The glass industry, fabricators, distributors and installers neither condones nor recommends any scraping of glass surfaces with metal blades or knives. Such scraping usually permanently damages or scratches the glass surfaces. When paint or other construction materials cannot be removed with normal cleaning procedures, a new 25mm razor blade may have to be used. The razor blade should be used on small spots only. Cleaning should be done in one direction only. Never scrape in a back and forth motion as this could trap particles under the blade that could scratch the glass.

Blades or scrapers can dislodge "pickup" on toughened glass. There are fine particles of glass that are fused on to the surface during toughening. Once dislodged they can scratch the glass.

Glass Cleaning, Do's and Don'ts

DO NOT..

- Do Not - Use Scrapers of any type or size on a Glass surface
- Do Not - Leave building dirt or residues to remain on Glass for a period of time.
- Do Not - Begin cleaning glass until you have identified the surface type.
- Do Not - Clean Glass surfaces in direct sunlight.
- Do Not - Allow dirty water or cleaning residues to remain on the Glass.
- Do Not - Begin cleaning before rinsing off a loose residues.
- Do Not - Use abrasive cleaning solutions, materials or solvents.
- Do Not - Allow metal parts of the cleaning equipment to come in contact with the Glass.
- Do Not - Trap abrasive particles between the cleaning material and the Glass.

DO...

- Clean glass promptly when dirt or building residues appear.
- Determine glass surface type.
- Exercise special care when cleaning coated surfaces.
- Avoid cleaning glass surfaces in direct sunlight.
- Start cleaning at the top of a building, then continue to lower levels.
- Soak the glass surface in a clean soapy solution before cleaning.
- Use a mild non abrasive commercial cleaner.
- Use a squeegee to remove all cleaning solution.
- Try your procedures on a small window and check.
- Caution other trades re the care and protection of the glass surfaces.

**Residues of surface grit may be present from the toughening production process.
These grit particles must not be dragged across the surface.
NEVER use Metal Scrapers**

All above reprinted with permission from Metro Glass Tech



Stainless Steel Care and Maintenance

Care and Maintenance of Stainless Steel

Introduction

Stainless steels are selected for applications where their inherent corrosion resistance, strength and aesthetic appeal are required. However, dependent on the service conditions, stainless steels will stain and discolour due to surface deposits and so cannot be assumed to be completely maintenance-free. In order to achieve maximum corrosion resistance and aesthetic appeal, the surface of the stainless steel must be kept clean. Provided the grade of stainless steel and the surface finish are correctly selected, and cleaning schedules carried out on a regular basis, good performance and long service life will result.

For the correct selection of a Stainless Steel grade, with respect to Location, see Table below.

Factors affecting maintenance

Surface contamination and the formation of deposits on the surface of the stainless steel must be prevented. These deposits may be minute particles of iron or rust generated during construction. Industrial and even naturally occurring atmospheric conditions can produce deposits which can be equally corrosive, e.g. salt deposits from marine conditions.

Working environments can also provide aggressive conditions such as heat and humidity in swimming pool buildings. These conditions can result in surface discolouration of stainless steels and so maintenance on a more frequent basis may be required.

Modern processes use many cleaners, sterilizers and bleaches for hygienic purposes. Proprietary solutions, when used in accordance with makers' instructions, should be safe but if used incorrectly (e.g. warm or concentrated), may cause discolouration or corrosion on stainless steels. Strong acid solutions are sometimes used to clean masonry and tiling of buildings. These acids should never be used where contact with metals, including stainless steel, is possible. If this happens, the acid solution must be removed immediately, followed by dilution and rinsing with clean water.

Maintenance programme

With care taken during fabrication and installation, cleaning before 'hand-over' should not present any problems. More attention may be required if the installation period has been prolonged or hand-over delayed. Where surface contamination is suspected, immediate cleaning after site fixing should avoid problems later.

The frequency of cleaning is dependent on the application. This may vary from once to four times a year for external applications, Recommendations on cleaning frequencies in architectural applications are shown below.

Cleaning frequency

Reccommended Cleaning for various grades of Stainless Steel		
Location	304 Grade	316 Grade
Surbarban or Rural	Clean at 6-12mth intervals or as necessary	
Industrial or Urban	Clean at 3-6mth intervals	Clean at 6-12mth intervals
Coastal or Marine	Not recommended	